



CMOS Multi-Function Analog Laser Sensor

IL Series



Thickness differentiation

Seam detection

Thickness differentiation

Height control



INTRODUCING THE LASER APPLICATION SENSOR IL SERIES

HEIGHT/HEIGHT DIFFERENCE
WARPAGE
THICKNESS/WIDTH

POSITIONING
FEEDBACK LOOP CONTROL
PEAK, BOTTOM AND PEAK TO PEAK

MAX. 3.5 m

NEW SENSOR HEAD RELEASED

ULTRA-LONG TYPE

A VARIETY OF USES AT LOW COST

COMPACT AND LIGHTWEIGHT LASER DISPLACEMENT SENSOR

Intelligent

High repeatability was achieved by using state of art technology and functions specifically developed for measuring instruments.

Rugged

Developed for use in harsh environments, the IL Series was designed with a robust structure.

Easy

Excellent usability makes it possible to quickly and easily perform stable measurements without any difficult adjustments or settings.



The intelligent I-Series consists of a highly stable sensor lineup that realizes low-cost and high performance with only the most advanced functions for on-site operations.

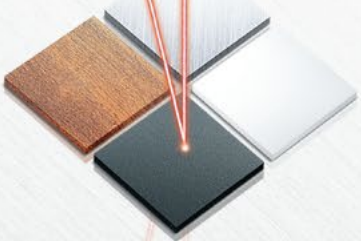

SUPER SMALL HEAD + MULTI-FUNCTION AMPLIFIER

[Measurement with higher stability] + [All-in-one design]

The IL Series automatically controls and optimizes laser power according to the reflectance of the target. As a result, stable measurement is possible for almost any target from black rubber to highly reflective metal surfaces. Furthermore, in order to further streamline communication with process control systems we have installed application specific functions into the compact amplifier.

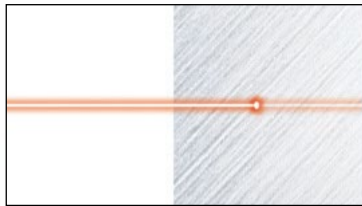

Reduced power

When the workpiece is highly reflective

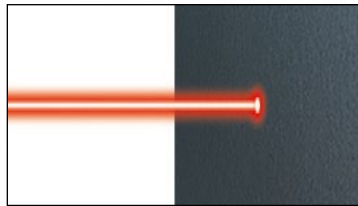

Increased power

When the workpiece is dark

RUGGED HEAD STRUCTURE

[Die cast metal used for IP67/optical base]

The head structure was redesigned to make it rugged enough to withstand almost any environment. In addition, the optical base is made of die cast SUS304 for added strength and protection.



KEYENCE LINEUP OF SENSOR HEADS

IL SERIES CMOS MULTI-FUNCTION ANALOG LASER SENSOR

IL-030

Reference distance
30 mm 1.18"
Measurement range
25 mm 0.98"



Measurement range from Head : 20 to 45 mm 0.79" to 1.77"
Repeatability: 1 μ m
Linearity: $\pm 0.1\%$ of F.S.

IL-065

Reference distance
65 mm 2.56"
Measurement range
50 mm 1.97"



Measurement range from Head : 55 to 105 mm 2.17" to 4.13"
Repeatability: 2 μ m
Linearity: $\pm 0.1\%$ of F.S.

IL-100

Reference distance
100 mm 3.94"
Measurement range
55 mm 2.17"



Measurement range from Head : 75 to 130 mm 2.95" to 5.12"
Repeatability: 4 μ m
Linearity: $\pm 0.15\%$ of F.S.

IL-2000

Reference distance
2000 mm 78.74"
Measurement range
2500 mm 98.43"



Repeatability: 100 μ m
Linearity: $\pm 0.16\%$ of F.S.

Measurement range from Head

0 20 40 60 80 100 120 140 160 180 200 300 400 500 600 700 800 900 1000 1100 1200 1

Dynamic range of x 1 million,
 Lineup of 6 heads according to applications ranging from 20 mm to 3500 mm **0.79" to 137.80"**

IL-300

Reference distance
 300 mm **11.81"**
 Measurement range
 290 mm **11.42"**



Measurement range from Head : 160 to 450 mm **6.30" to 17.72"**

Repeatability: 30 μ m
 Linearity: $\pm 0.25\%$ of F.S.

IL-600

Reference distance
 600 mm **23.62"**
 Measurement range
 800 mm **31.50"**



Measurement range from Head : 200 to 1000 mm **7.84" to 39.37"**

Repeatability: 50 μ m
 Linearity: $\pm 0.25\%$ of F.S.

0 20 40 60 80 100 120 140 160 180 200 300 400 500 600 700 800 900 1000

Measurement range from Head : 1000 to 3500 mm **39.37" to 137.80"**

THE LONGEST IN ITS CLASS

3.5 m
11.48 ft

300 1400 1500 1600 1700 1800 1900 2000 2100 2200 2300 2400 2500 2600 2700 2800 2900 3000 3100 3200 3300 3400 3500 3600 3700 3800 3900 4000

THE MULTI-FUNCTION AMPLIFIER WITH AN ALL-IN-ONE DESIGN

New mode – Thickness calibration function included

3-step easy calibration With conventional devices, calibration had to be conducted on each and every individual sensor head, however, as the IL Series has a dedicated mode that allows calibration to be completed in 3 simple steps.

Step 1 Bring the target close to one sensor head and input the thickness data, then push the set button.

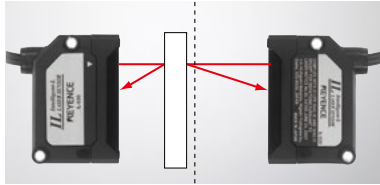

Step 2 Bring the same target used in Step 1 close to the opposing sensor head and push the set button.

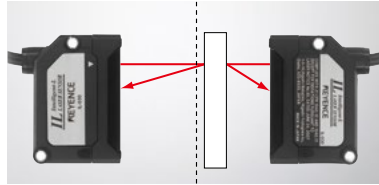

Step 3 Insert a target thicker than the target used in Step 2. Input the thickness data. Then pushing the set button completes calibration.

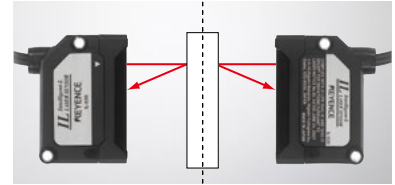

When bringing the target closer to the sensor head in Steps 1 and 2, you are compensating for the misalignments that occur during installation. To set, you can begin with either one of the sensor heads.

Ambient light elimination function included

In order to counteract any ambient light interference, the IL Series automatically activates the ambient light elimination function when the sampling cycle is set to '2 ms' or '5 ms', reducing the effects of ambient light.

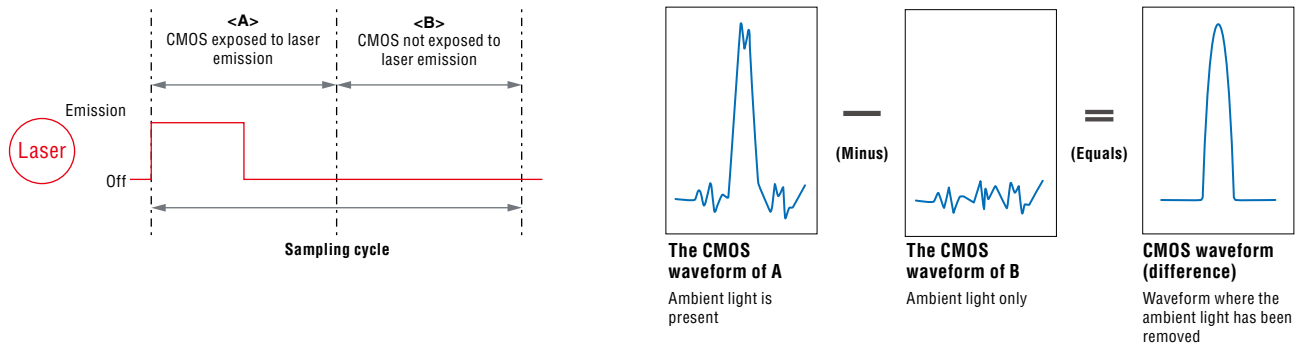

Height difference filter function included

This function identifies step edges automatically and delivers one-shot output for each step. Create settings for count and seam detection applications easily, without the programming hours.

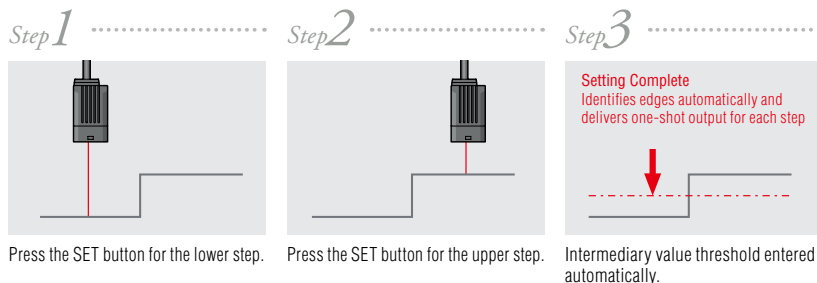

Differentiate between sheets of printed material

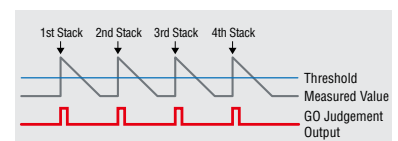
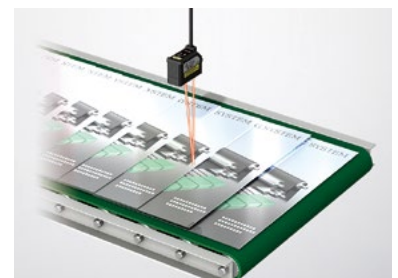

Multi-function amplifier Calculation Function

Addition mode

Setting example 1
(thickness measurement)

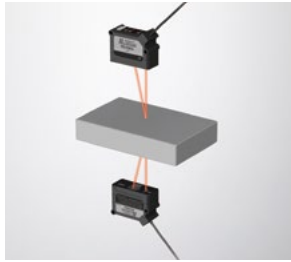

Setting example 2
(width measurement)

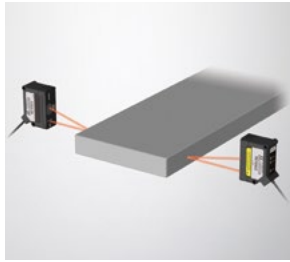

Subtraction mode

Setting example 1
(Measurement of height difference)

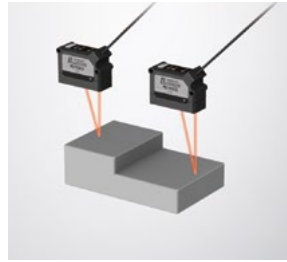

Setting example 2
(Measuring tilt)

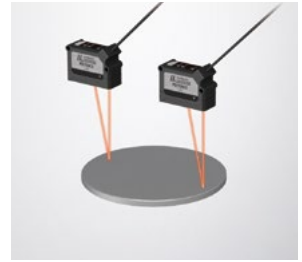

High pass filter function included

This function displays measured values above the adjustable cutoff frequency and ignores changes below that cutoff. It is effective for filtering out natural runout and measuring seams or defects.

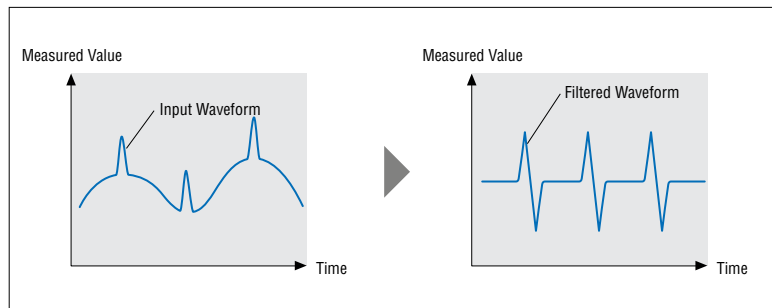

Detection on the edge of a sheet



Function choices

NPN/PNP Output Selection (judgement selection)

Both NPN and PNP outputs are supported. The outputs are set the first time the user turns on the power. These settings can subsequently be changed. Judgements are output as HIGH, GO, or LOW.

Analog Output Selection

The following five types of analog outputs can be selected. The output is selected the first time the user turns on the power.

Setting value	Description
OFF	Not output
0-5V	Analog output after the judgement value is converted to the range from 0 to 5 V.
-5-5V	Analog output after the judgement value is converted to the range of ±5 V.
1-5V	Analog output after the judgement value is converted to the range from 1 to 5 V.
4-20mA	Analog output after the judgement value is converted to the range from 4 to 20 mA.

The setting can be changed.

Bank Function

The bank function can register up to four patterns of specific settings.* For example, in response to a measurement target changeover, this function allows the user to easily switch between the patterns of registered settings.

* HIGH setting value, LOW setting value, shift value, analog output scaling setting

Mounting method options

Both panel and DIN-rail mount units are available.



OPEN FIELD NETWORK UNIT

CHANGING THE FACE OF FACTORY AUTOMATION

The DL Series supports communication with open field networks.

IG Series

Multi-Purpose CCD Laser Micrometer

GT2/GT Series

Contact Sensor

IB Series

Thru-beam Type Laser Detection Sensor

IL Series

CMOS Multi-function Analog Laser Sensor

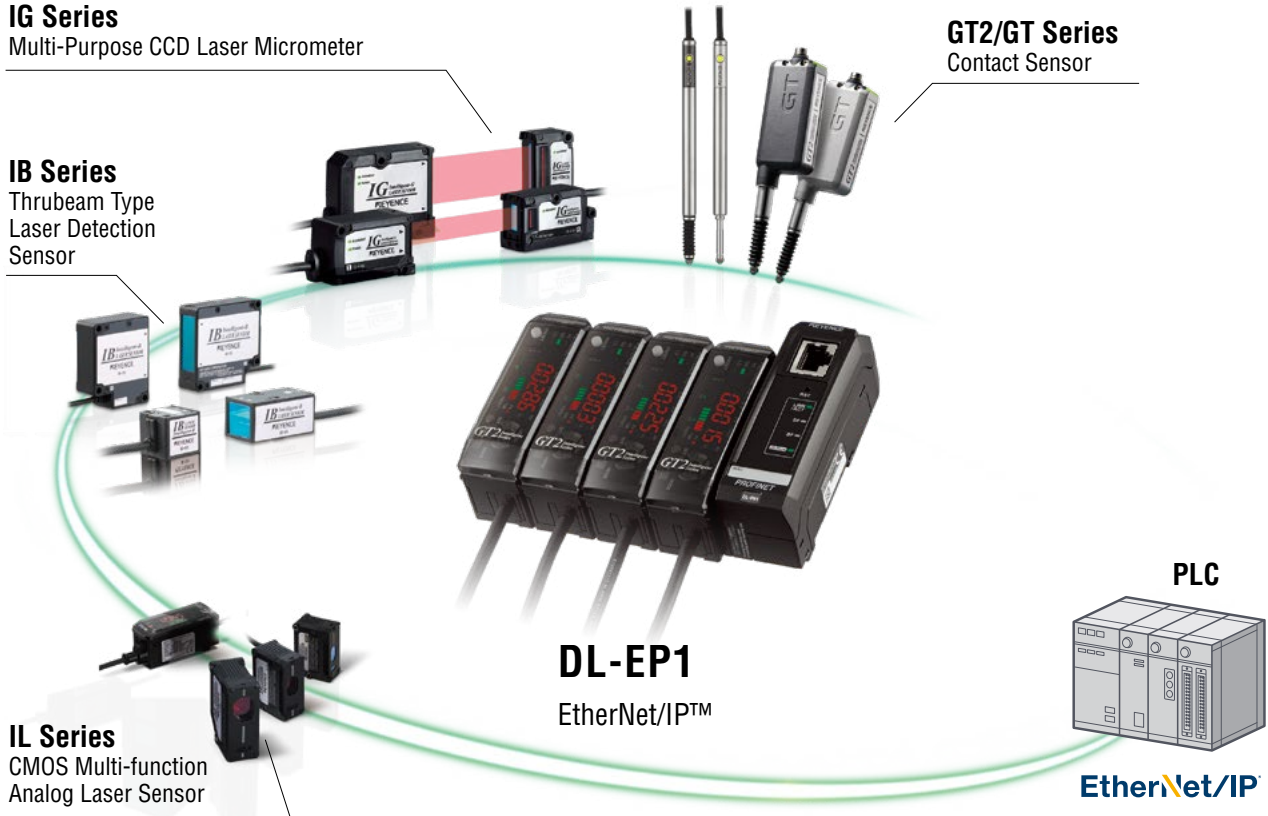

DL Series lineup

The IL Series supports various networks with its lineup of communication units.

COMMUNICATIONS	OPEN FIELD NETWORK	Protocol	Model	Brand
		Ethernet (TCP/IP)	DL-EN1	TCP/IP
		EtherCAT®	DL-EC1A	EtherCAT®
		EtherNet/IP™	DL-EP1	EtherNet/IP™
		PROFINET	DL-PN1	PROFINET
		PROFIBUS	DL-PD1	PROFIBUS
		DeviceNet®	DL-DN1	DeviceNet®
		CC-Link	DL-CL1	CC-Link V2
		RS-232C communication	DL-RS1A	

EtherCAT® is registered trademark and patented technology, licensed by Beckhoff Automation GmbH, Germany.

APPLICATIONS

Height difference measurements of a plastic extrusion

Provides constant monitoring by measuring the height using 2 sensors simultaneously, then calculates the height difference using the calculation function in the amplifier. Reliable detection is possible even if the product type or color changes.

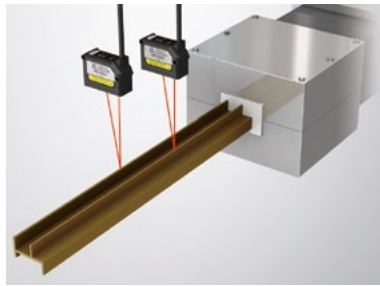

Warpage detection in ceramic boards

As the sensor head is compact, multiple point measurements of small-scale boards are possible. By calculating the measurement data externally, simultaneous measurements of positioning and warpage are possible.

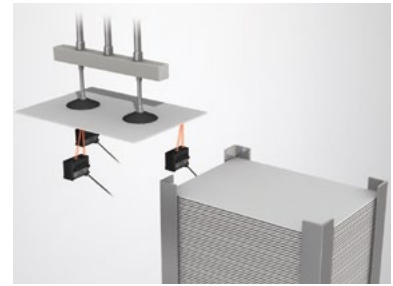

Thickness/width measurements of building material boards

Thickness and width can be simultaneously measured immediately after the extrusion process. In addition, man-hours for setup and product changeovers are reduced using the thickness calibration function.

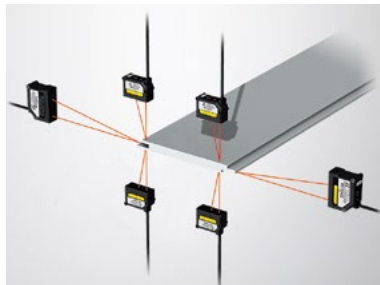

Packaging material counting

Even in targets with a large amount of shape scatter, reliable counts can still be achieved by detecting rising edges. The output signal is then sent to a counter or other device.



Accuracy checks on an automotive door assembly

When assembling automotive doors, by simultaneously measuring multiple points, the assembly accuracy can be evaluated. Reliable detection is possible regardless of body color.

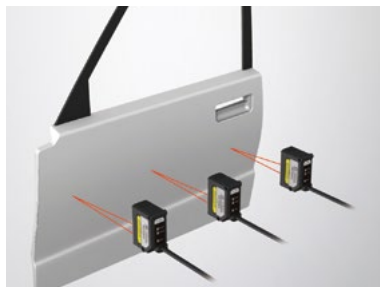

Position control of weld beads

Through external calculations of height data from the sensor, the device detects the position of the weld seam. Welding accuracy can be improved via measurement data feedback to the welder.



Heat processing inspection of cans

By observing the expansion displacement of a can after heat processing, the results of heat processing can be evaluated. Reliable differentiation can still be conducted even if there are color changes in the cans.

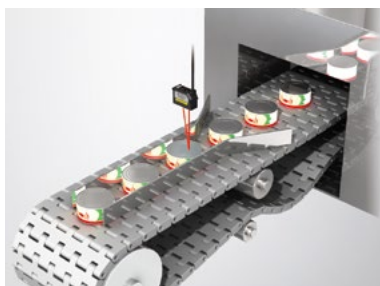

Sag detection of web material

By using a long range type of sensor head, it is possible to control height of hoop materials such as steel plates and sheet materials even during transportation. The sensor head can be installed at a distance of up to 3000 mm 118.11".

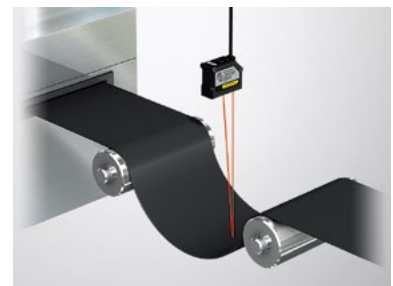

Differentiation of different types of plastic components

Reliable differentiation, even of highly variable small parts is possible, using a high-precision sensor head. External changeover of up to 4 patterns is possible by setting items in the bank function.

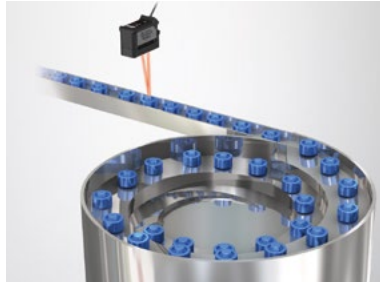

Stacker device counts and stacking disturbances

The IL Series identifies items are being transported along a conveyer, in addition to the non-contact detection of uneven stacking in the stacker. Reliable detection regardless of color changes in the targets.



Wire winding process

Prevents irregular winding by monitoring the traverser position. In addition, feedback control to the device is possible by measuring the volume wound into the bobbin at the same time.

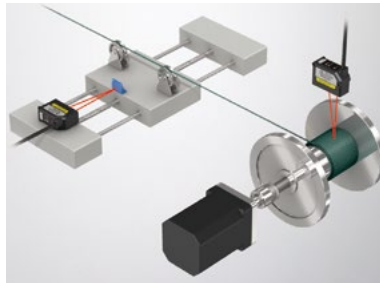

Height controls of a PC board

Controls the PC board height in the mounting and drilling processes. Various kinds of targets can be reliably controlled without being affected by the surface colors of the PC boards.



Detect the position of the workpiece on a pallet being carried on a conveyor

Detect the position of the workpiece that was stacked on a pallet by a palletizer. The stable detection is enabled despite of the color change and the slant of the workpiece.



Detect whether or not the workpiece remains in the die

Confirm whether or not the workpiece is removed from the die, which prevents the die from being damaged in advance. Using the ultra-long type enables the stable detection without concern for installation distance.

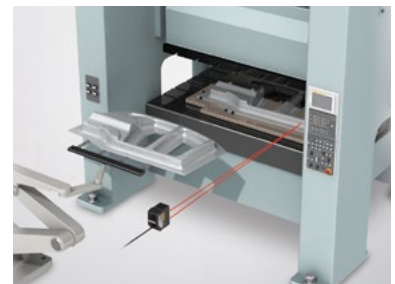

Aluminum melt level detection

Using the ultra-long type enables installation at a maximum distance of 3500 mm [137.80°](#) without worry for the ambient temperature.



Measuring the height of a chip after bonding

Measures the height of the board pre-bonding and the chip post-mounting, allowing control of the post-processing suction nozzle and dispenser nozzle feedback.



Robot arm positioning

Detect robot arm chuck precision on the X-, Y- and Z-axes. The long range head enables detection from long distances.



Rubber sheet seam detection

Detect seams in rubber sheets. Sensors above and below the workpieces enable stable detection, even when the sheets are inverted.

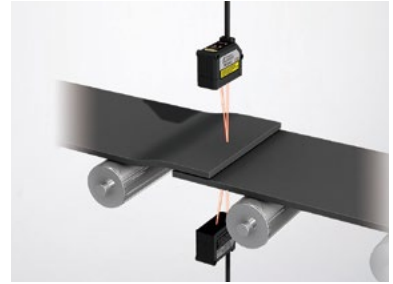

Roll chuck position detection

Detect the position of roll chucks for film winding. Save a huge amount of adjustment time, even for different equipment.

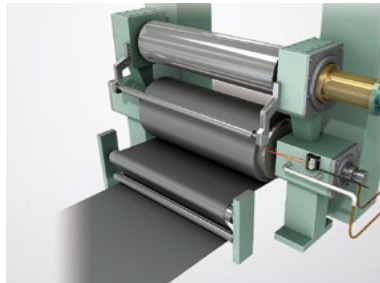

Press processing thickness differentiation

Differentiate between steel plates or detect two sheets going through at once with thickness differentiation in the press process. The long range head enables differentiation from long distances, even for large sized pressing.



Liquid level detection in a tank of chocolate

This device constantly monitors the level of liquid surfaces without contacting the liquid. Using a long range head makes it possible to detect levels from far away, even in tight spaces.



Control sheet roll diameter

Control feed speed and tension with constant monitoring of sheet diameter during winding and unwinding processes.



Detect H-beam flange warp

Detect the warp of H-beam flanges at multiple points before using a correction mechanism. Use a long range head for compatibility with many different targets.

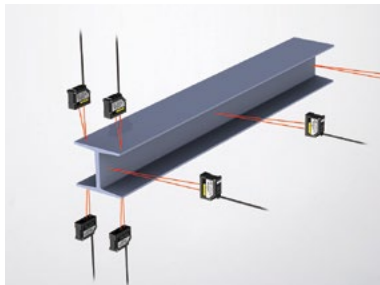

Control welding torch height

Control the height of welding torches. Boost welding precision through constant monitoring.

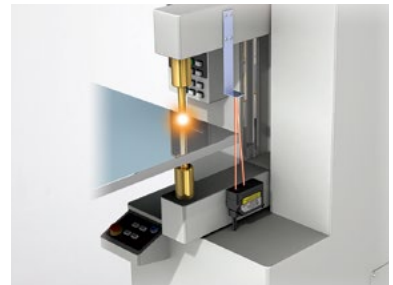

SPECIFICATIONS



Sensor heads

Model	IL-030	IL-065	IL-100	IL-300	IL-600	IL-2000
Appearance						
Reference distance	30 mm 1.18"	65 mm 2.56"	100 mm 3.94"	300 mm 11.81"	600 mm 23.62"	2000 mm 78.74"
Measurement range	20 to 45 mm 0.79" to 1.77"	55 to 105 mm 2.17" to 4.13"	75 to 130 mm 2.95" to 5.12"	160 to 450 mm 6.30" to 17.72"	200 to 1000 mm 7.84" to 39.37"	1000 to 3500 mm 39.37" to 137.80"
Light source	Red semiconductor laser, wavelength: 655 nm (visible light)					
	Class 1 (FDA (CDRH) Part1040.10) ¹ Class 1 (IEC 60825-1)			Class 2 (FDA (CDRH) Part1040.10) ¹ Class 2 (IEC 60825-1)		
	220 µW			560 µW		
Spot diameter (at standard distance)	Approx. 200 × 750 µm	Approx. 550 × 1750 µm	Approx. 400 × 1350 µm	Approx. ø0.5 mm ø0.02"	Approx. ø1.6 mm ø0.06"	Approx. 1400 × 7000 µm
Linearity ^{2,3}	±0.1% of F.S. (25 to 35 mm 0.98" to 1.38")	±0.1% of F.S. (55 to 75 mm 2.17" to 2.95")	±0.15% of F.S. (80 to 120 mm 3.15" to 4.72")	±0.25% of F.S. (160 to 440 mm 6.30" to 17.32")	±0.25% of F.S. (200 to 600 mm 7.84" to 23.62") ±0.5% of F.S. (200 to 1000 mm 7.84" to 39.37")	±0.16% of F.S. (1000 to 3500 mm 39.37" to 137.80")
Repeatability ⁴	1 µm	2 µm	4 µm	30 µm	50 µm	100 µm
Sampling rate	0.33/1/2/5 ms (4 levels available)					
Operation status indicators	Laser emission warning indicator: Green LED, Analog range indicator: Orange LED, Reference distance indicator: Red/Green LED					
Temperature characteristics ³	0.05% of F.S./°C	0.06% of F.S./°C	0.06% of F.S./°C	0.08% of F.S./°C		0.016% of F.S./°C
Environmental resistance	Enclosure rating	IP67				
	Ambient light ⁵	Incandescent lamp: 5000 lux	Incandescent lamp: 7500 lux	Incandescent lamp: 5000 lux		Incandescent lamp: 10000 lux
	Ambient temperature	-10 to +50°C 14 to 122°F (No condensation or freezing)				
	Relative humidity	35 to 85% RH (No condensation)				
	Vibration	10 to 55 Hz Double amplitude 1.5 mm 0.06" XYZ each axis: 2 hours				
Pollution degree	3					
Material	Housing material: PBT, Metal parts: SUS304, Packing: NBR, Lens cover: Glass, Cable: PVC					
Weight	Approx. 60g	Approx. 75g		Approx. 135g		Approx. 350g

1. The laser classification for FDA (CDRH) is implemented based on IEC 60825-1 in accordance with the requirements of Laser Notice.

2. Value when measuring the KEYENCE standard target (white diffuse object).

3. F.S. of each model is as follows. IL-030: ±5 mm ±0.20" IL-065: ±10 mm ±0.39" IL-100: ±20 mm ±0.79" IL-300: ±140 mm ±5.51" IL-600: ±400 mm ±15.75"

4. Value when measuring the KEYENCE standard target (white diffuse object) at the reference distance, sampling rate: 1 ms, and average number of times: 128. For the IL-300/IL-600, the sampling rate is 2 ms.

5. Value when the sampling rate is set to 2 ms or 5 ms.

Amplifier unit

Model	IL-1000	IL-1500	IL-1050	IL-1550
Appearance				
Type	DIN-rail mount	Panel mount	DIN-rail mount	Panel mount
Main unit/expansion unit	Main unit		Expansion unit	
Head compatibility	Compatible			
Display	Minimum displayable unit: IL-030: 1 µm, IL-065/IL-100: 2 µm, IL-300: 10 µm, IL-600: 50 µm, IL-2000: 100 µm 3.94"			
	Display range: IL-030/IL-065/IL-100: ±99.999 mm to ±99 mm (4 levels selectable), IL-300/IL-600: ±999.99 mm to ±999 mm (3 levels selectable), IL-2000: ±9999.9 mm to ±9999 mm (2 levels selectable)			
	Display rate: Approx. 10 times/sec.			
Analog voltage output ¹	±5 V, 1 to 5 V, 0 to 5 V Output impedance 100 Ω		None	
Analog current output ¹	4 to 20 mA Maximum load resistance of 350 Ω		None	
Control input ²	Bank switch input			
	Zero-shift input			
	Stop emission input			
	Timing input			
	Reset input			
Control output ³	Judgement output: Open collector output (NPN, PNP changeover possible/N.O., N.C. changeover possible)			
	Alarm output: Open collector output (NPN, PNP changeover possible/N.C.)			
Current	Power voltage ⁴ : 10 to 30 VDC ripple (P-P) 10% included, Class 2		Supplied by main unit	
	Power consumption: 2300 mW or less (at 30 V: 77 mA or less)		2500 mW or less (at 30 V: 84 mA or less)	
Environmental resistance	Ambient humidity: -10 to +50°C 14 to 122°F (No condensation or freezing)			
	Ambient temperature: 35 to 85% RH (No condensation)			
	Vibration: 10 to 55 Hz Double amplitude 1.5 mm 0.06" XYZ each axis: 2 hours			
	Pollution degree: 2			
Material	Case / Front sheet: Polycarbonate; Key tops: Polyacetel; Cable: PVC			
Weight (including attachments)	Approx. 150g	Approx. 170g	Approx. 140g	Approx. 160g

1. Select and use one of ±5 V, 1 to 5 V, 0 to 5 V or 4 to 20 mA.

2. Assign an input of your choice to the 4 external input lines before using.



3. – The NPN open collector rated output is: 50 mA max./ch (20 mA when adding an expansion unit) less than 30 V, residual voltage less than 1 V (less than 1.5 V when adding over 6 units including the main unit)

– The PNP open collector rated output is: 50 mA max./ch (20 mA/ch when adding expansion units), less than power voltage, and less than 2 V residual voltage (less than 2.5 V when adding over 6 units including the main unit)

4. If there are over 6 additional expansion units, please use a power voltage of 20 to 30 V.

Sensor head cables (sold separately)

The cable does not come attached with the sensor head and must be purchased separately.







Type	Appearance	Cable length	Model	Weight
Straight	1 cable included 	2 m 6.56'	OP-87056	Approx. 80 g
		5 m 16.40'	OP-87057	Approx. 190 g
		10 m 32.80'	OP-87058	Approx. 360 g
		20 m 65.62'	OP-87059	Approx. 680 g
L-shaped	1 cable included 	2 m 6.56'	OP-87660	Approx. 80 g
		5 m 16.40'	OP-87661	Approx. 190 g
		10 m 32.80'	OP-87662	Approx. 360 g
		20 m 65.62'	OP-87663	Approx. 680 g

This connector is required if the cable is cut.



Connector used to connect to a display unit (2 pcs.)
OP-84338

Optional

Type	Appearance	Model	Description	Weight
End unit (Optional)		OP-26751	To connect an additional expansion unit, use the end units to secure the display units on both ends. When connecting additional units, be sure to use the end units. (2 pcs.)	Approx. 15 g
Panel front protection cover [Included in panel mount type amplifier]		OP-87076	The panel front protection cover and panel mounting bracket are included in the panel mount type amplifier. If the supplied cover or bracket is lost or damaged, purchase a new one.	Approx. 6 g
Panel mounting bracket [Included in panel mount type amplifier]		OP-4122		Approx. 7 g
Expansion cable		OP-35361 (300 mm 11.81')	Extension cable used for panel mount type amplifier. Use this cable if the standard cable is not long enough.	Approx. 10 g
DIN-rail mounting bracket		OP-60412	The mounting bracket is used when the expansion cable is used to connect to the panel mount type display unit, in which case a DIN rail is not provided.	Approx. 12 g
Mounting bracket		OP-87606	Mounting bracket for IL-2000	Approx. 338 g
Sensor head relay cable		OP-87431 (3.5 m 11.5')	M8-M8 relay cable	Approx. 165 g
		OP-87432 (7.5 m 24.6')		Approx. 275 g
		OP-87433 (9.0 m 29.5')		Approx. 360 g

WIRING DIAGRAM

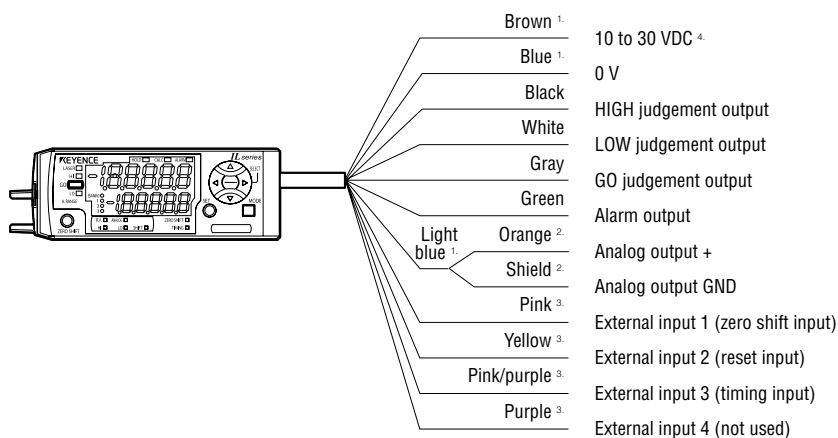

- The brown, blue, and light blue cables are not provided in a IL-1050/IL-1550 unit (expansion unit). The power is supplied to the expansion unit from the IL-1000/IL-1500 unit (main unit).
- For an analog output, OFF (not used), 0 to 5 V, ± 5 V, 1 to 5 V, or 4 to 20 mA can be selected.
- For an external input, bank A input, bank B input, laser emission stop input, or OFF (not used) can also be selected. For details, refer to the User's Manual.
- If there are over 6 additional expansion units, please use a power voltage of 20 to 30 V.

Warning/explanatory label for class 2 laser product

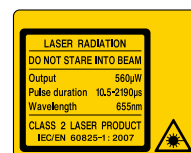

IL-030

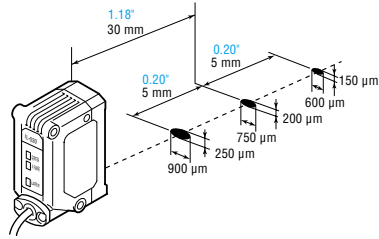

IL-065

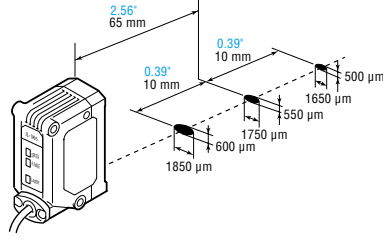

IL-100

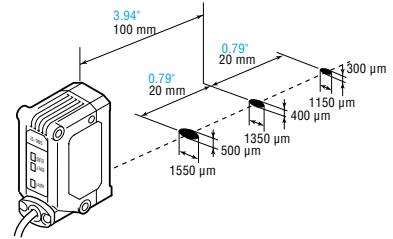

IL-300

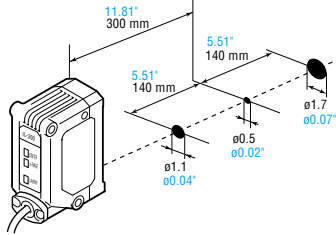

IL-600

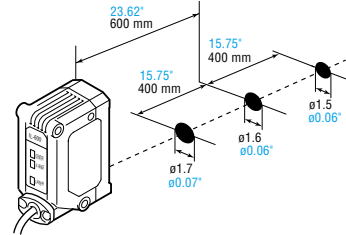

IL-2000

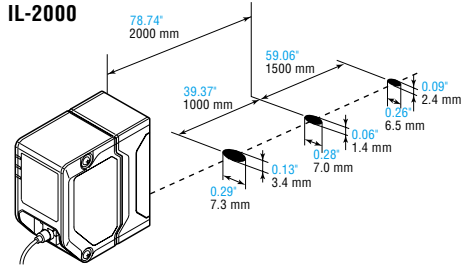

Amplifier unit (DIN-rail mount type)

IL-1000/IL-1050



IL-1000

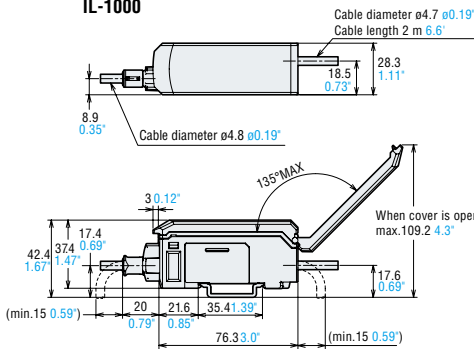

IL-1050

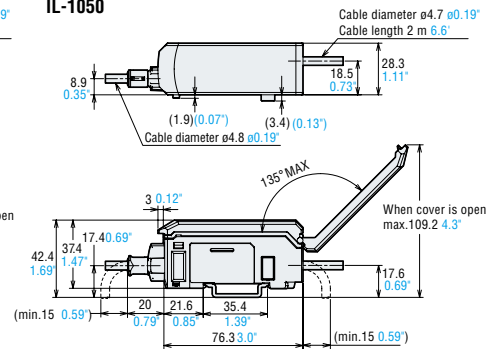

Amplifier unit (Panel mount type)

IL-1500/IL-1550

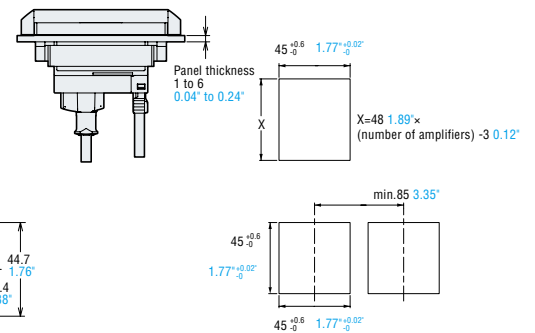
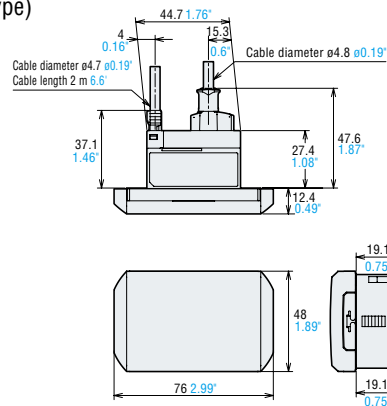

RELATED PRODUCT

HIGH-ACCURACY DIGITAL CONTACT SENSOR

GT2
SERIES

Unsurpassed accuracy and durability



Display resolution	: 0.1 μm ~
Precision	: 1 μm ~
Spindle movements	: ~200 million
Enclosure rating	: NEMA Type 13, IP67G

*NEMA Type 13: GT2-P12K(F)/P12(F) Only

A contact sensor built on new technologies that never experiences tracking errors or forgets the origin position, all thanks to the Scale Shot System II. *Except GT2-S1/S5

HIGHEST ACCURACY IN ITS CLASS	DISPLAY RESOLUTION	ACCURACY
	0.1 μm	1 μm

Technology of the Scale Shot System II

This innovative system was created based on KEYENCE's newly developed technology. High-intensity illumination from HL-LEDs reliably emits light through the absolute value glass scale to a high-resolution CMOS. Output signals are calculated by the I-Processor, which allows for constant position recognition. All these features are integrated into a slim 8mm 0.32" diameter body.

- HL-LED**
 These newly developed point light source LEDs provide even, high-intensity illumination which is 9 times more intense than conventional models.
*HL: High Luminance
- HIGH-RESOLUTION CMOS**
 With high sensitivity, this imaging element receives the LED light that passes through the absolute value glass scale and generates output signals with resolution twice that of conventional models.
- I-PROCESSOR**
 This IC is equipped with a new algorithm that performs high-speed, high-resolution calculation of the output signals transmitted from the CMOS sensor.

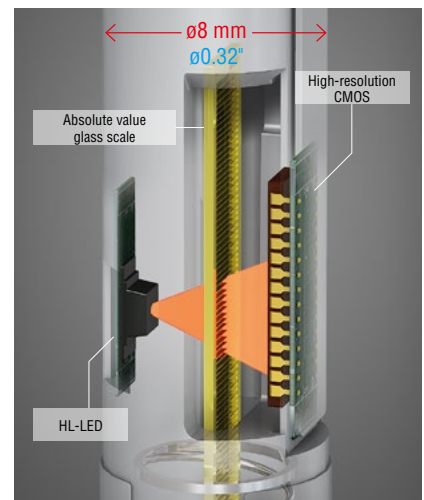

VERSATILE DETECTION MODES SUPPORT ALL APPLICATIONS

AUTOMOBILES

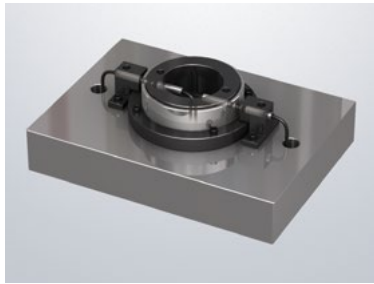

Inner and outer diameter measurement of components

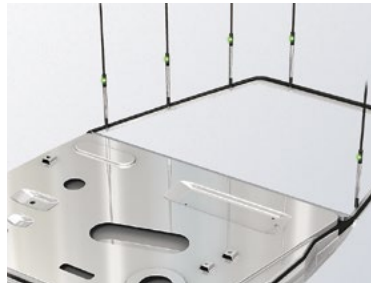

Door beam deformation check

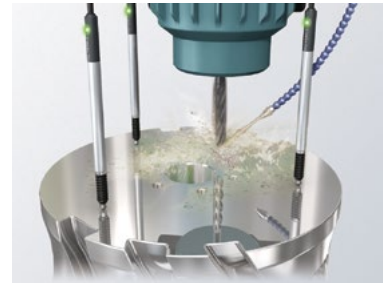

Disc assembly inspection



Camshaft runout measurement

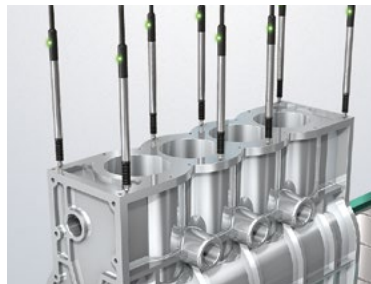

Flatness measurement of engine block



Oil pan flatness measurement

METALS



Bearing assembly inspection



Mill roll gap management

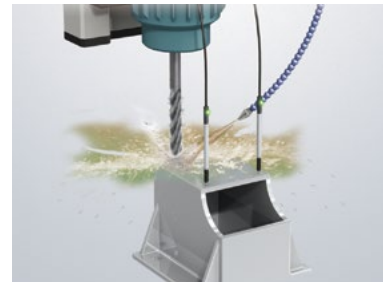

Dimensional measurement during machining

EQUIPMENT

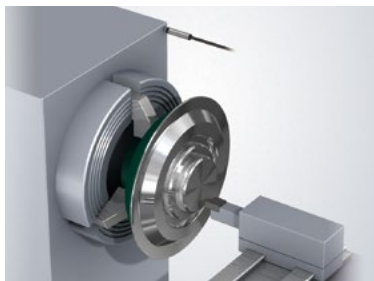

Machine tool stroke management

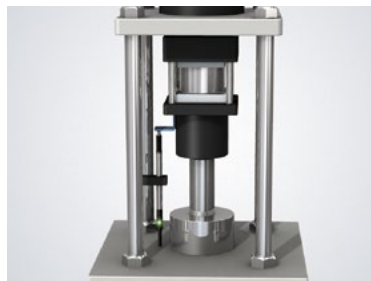

Assembly equipment press fitting inspection

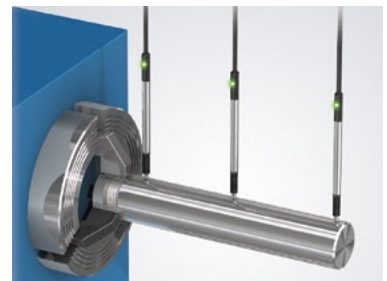

Product chucking confirmation

ELECTRONICS



Battery flatness check



Smartphone chassis flatness inspection

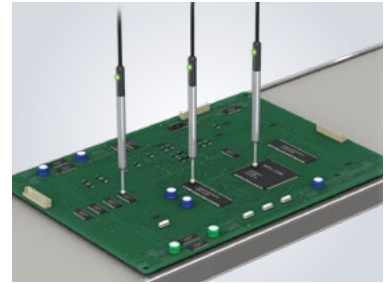

Board assembly check



Hard disk frame assembly inspection

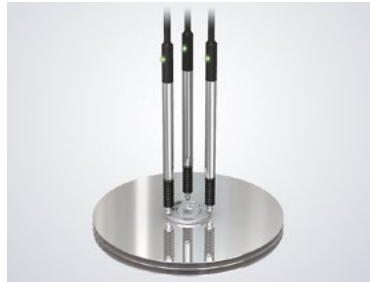

Hard disk clamp parallelism inspection

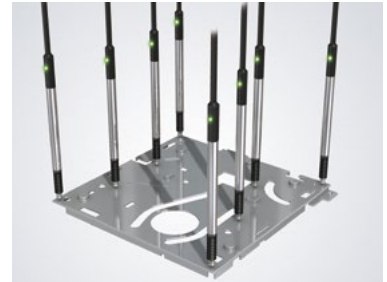

Chassis frame warpage inspection

SEMICONDUCTORS/LIQUID CRYSTALS



Polisher height control

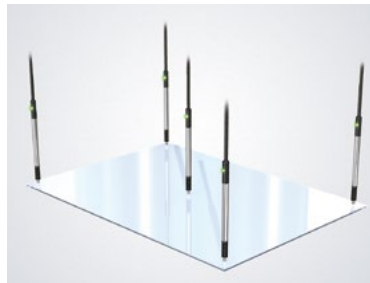

Liquid crystal panel flatness inspection

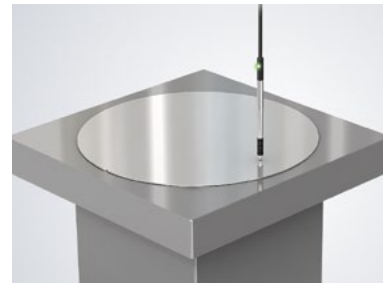

Wafer thickness measurement

FOOD/PRINTING



Double label stickers detection

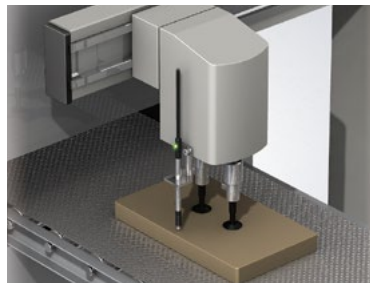

Workpiece suction check



Double feed detection

RELATED PRODUCT

MULTI-PURPOSE CCD LASER MICROMETER

IG SERIES Thrubeam Digital Laser Sensor with a High Level of Stability



Display resolution	: 1 μ m
Repeatability	: 5 μ m
Maximum installation distance	: 1500 mm 59.06"
Enclosure rating	: IP67

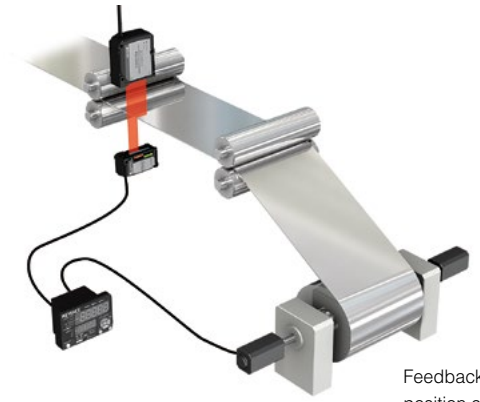

Feedback control using edge position control

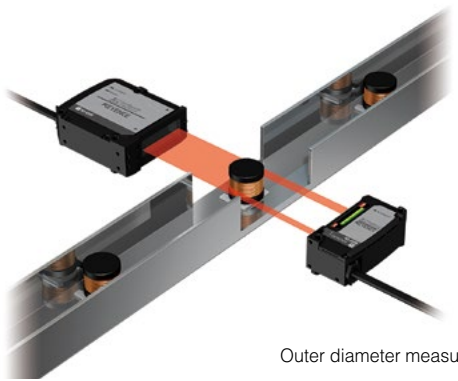

Outer diameter measurement of a part

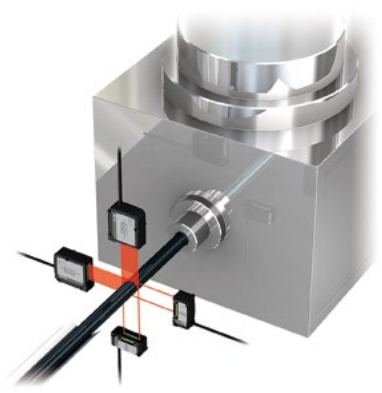

Outer diameter/deformation measurement an extrudate

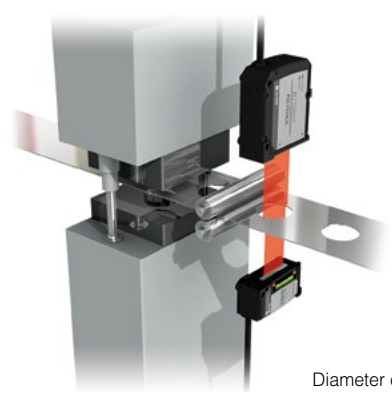

Diameter check of press cutting

HIGH-SPEED INLINE PROFILE MEASUREMENT DEVICE

LJ-V7000 Series



- 3D
- Multi-point
- Ultra-high-speed



Extrusion geometry inspection

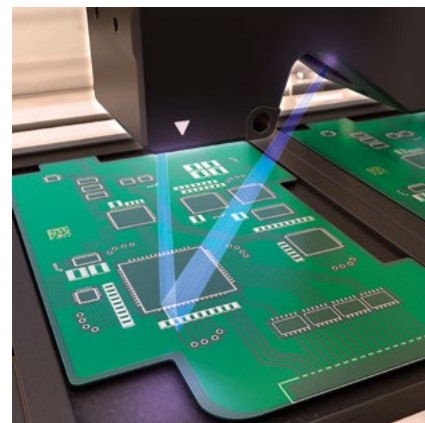

PCB component assembly inspection

LASER DISPLACEMENT

LK-G5000 Series



Fastest in the world

- Sampling rate of 392 kHz
- Linearity of $\pm 0.02\%$ of F.S
- Repeatability down to 0.01 μm

Connect up to 12 sensor heads/ network capable



Up to 12 heads connection

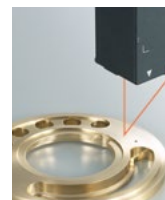

Metal surface



Mirror surface

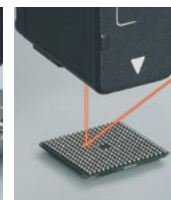

Diffuse reflection



Translucent surface



Transparent surface

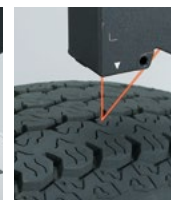

Black rubber

CONTACT YOUR NEAREST OFFICE FOR RELEASE STATUS

KEYENCE CORPORATION OF AMERICA

500 Park Boulevard, Suite 200, Itasca, IL 60143, U.S.A.

KEYENCE CANADA INC.

6775 Financial Dr., Suite 400, Mississauga, ON. L5N 0A4, Canada

KEYENCE MÉXICO S.A. DE C.V.

Av. Paseo de la Reforma 243, P11, Col. Cuauhtémoc, C.P. 06500, Del. Cuauhtémoc, Ciudad de México, México

☎ +1-201-930-0100 ✉ keyence@keyence.com

☎ +1-905-366-7655 ✉ keyencecanada@keyence.com

☎ +52-55-8850-0100 ✉ keyencemexico@keyence.com

CALL TOLL FREE

1-888-539-3623

1-888-KEYENCE

TO CONTACT YOUR LOCAL OFFICE

The information in this publication is based on KEYENCE's internal research/evaluation at the time of release and is subject to change without notice. Company and product names mentioned in this catalog are either trademarks or registered trademarks of their respective companies. The specifications are expressed in metric units. The English units have been converted from the original metric units. Unauthorized reproduction of this catalog is strictly prohibited.

Copyright © 2017 KEYENCE CORPORATION. All rights reserved.

03KA-2024-2

IL-KA-C5-US 2074-5 611E90