

KEYENCE

CMOS Multi-Function Analogue Laser Sensor

IL Series



“Stable Detection” Perfected

HIGHEST-FUNCTIONING MODEL IN ITS CLASS



20mm to 1m *1 μ m*

WIDE-RANGE

REPEATABILITY

EXCELLENT DIFFERENTIATION AT EXCELLENT PRICES

Intelligent sensor
I-SERIES

Excellent differentiation at excellent prices



MULTI-FUNCTION AMPLIFIER (INDICATOR)

All control specifications have been taken into consideration. Output is compatible with DeviceNet® and EtherNet/IP® in addition to analogue, RS-232C. This device comes standard equipped with a calculation function that adds or subtracts depending on the application as well as height difference count filter and high pass filter functions.

MEASUREMENT PRINCIPLE

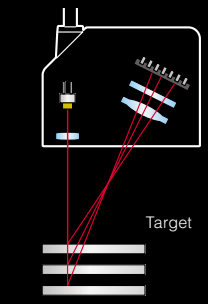

These devices use the principle of triangulation for measurement.

When the position of targets is altered, the position of the beam spot on the CMOS moves. These devices measure the displacement of targets by detecting the position of the beam spot.

1 μ m

REPEATABILITY

This is our lineup of devices with repeatability down to 1 μ m. Perform stable detection for a wide variety of applications with their dynamic range of x1.5 million light intensity control steps.

20mm to 1m

VARIATION RANGE

Our lineup of heads covers a wide range of applications, from short-range to ranges as ultra long as 1 m.



Panel mount type



DIN-rail mount type



CMOS Multi-Function Analogue
Laser Sensor
IL Series



An abundance of head variations for all applications

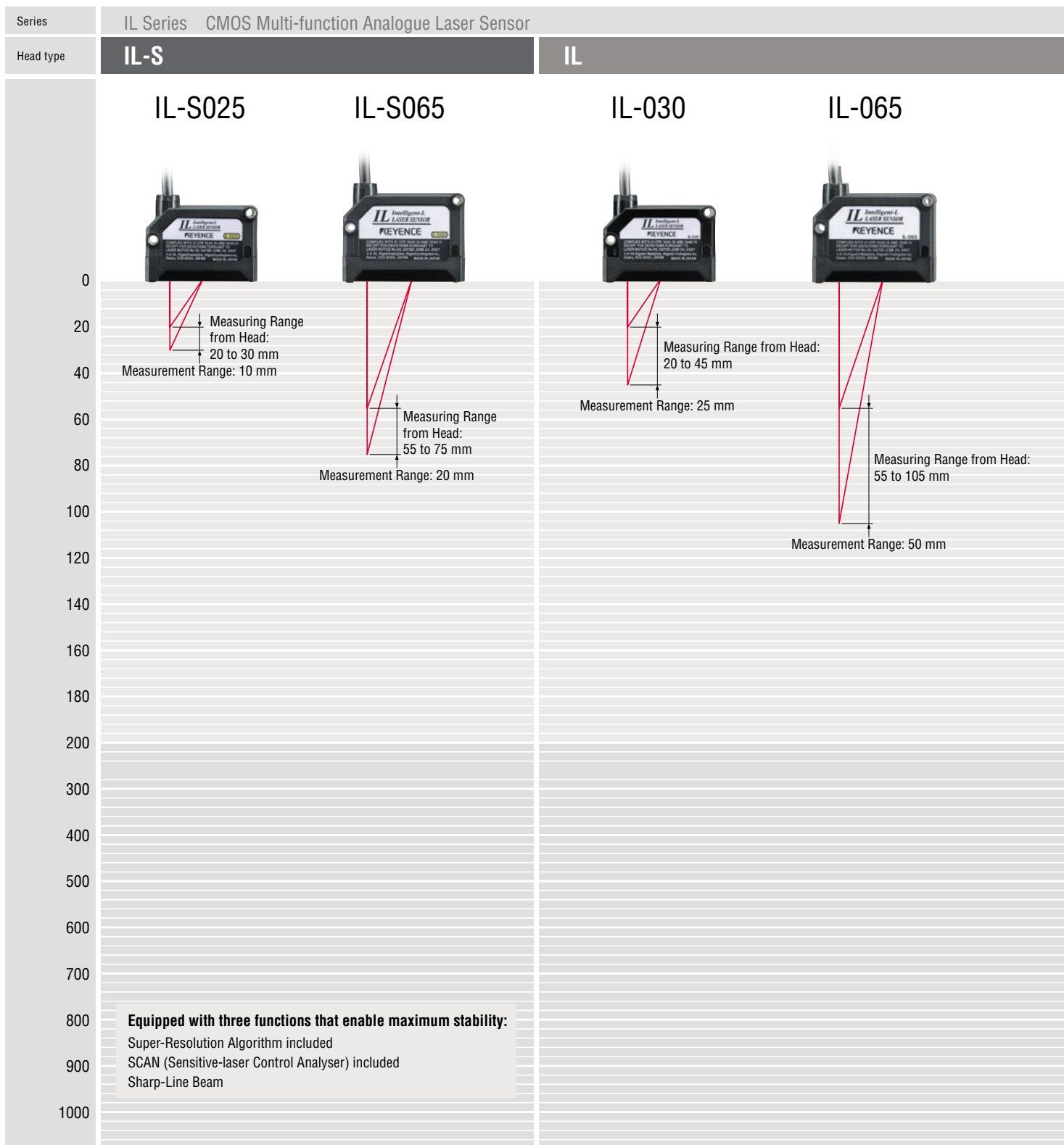

	IL-S025	IL-S065	IL-030	IL-065
Repeatability	1 μ m	2 μ m	1 μ m	2 μ m
Linearity	$\pm 0.075\%$ of F.S	$\pm 0.05\%$ of F.S	$\pm 0.1\%$ of F.S	$\pm 0.1\%$ of F.S
Reference distance	25 mm	65 mm	30 mm	65 mm

IL-100

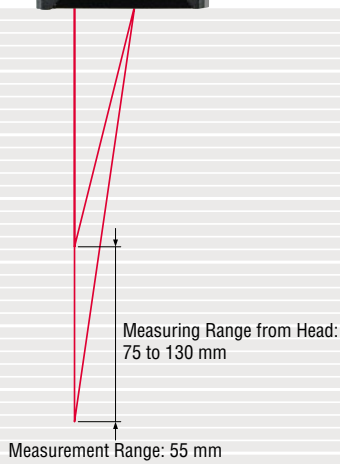

IL-300



IL-600



IL-100	IL-300	IL-600
4 μm	30 μm	50 μm
$\pm 0.15\%$ of F.S	$\pm 0.25\%$ of F.S	$\pm 0.25\%$ of F.S
100 mm	300 mm	600 mm

Introducing a high-performance head for the IL Series
Stable performance for the most demanding detection

IL-S Sharp-Line Sensor Heads

The transmitter is equipped with a cylindrical lens that enables sharp-line beams.

We have overhauled the signal processing inside the head and equipped the device with a Super-Resolution Algorithm so that it is the highest-functioning model in its class.



Equipped with Industry First Super-Resolution Algorithm

Repeatability 1 μ m

Linearity $\pm 0.05\%$ of F.S.

Dynamic Range (x1.5 million)

Equipped with three functions that enable maximum stability

Super-Resolution Algorithm included Industry First

This algorithm identifies differences in CMOS received light waveforms generated by changes in surface conditions of target workpiece and automatically processes waveforms in the best manner possible. Now, you can perform stable detection without tuning, even on metal hairlines, plastic, rubber and other workpiece that has always been difficult to detect.

SUPER-RESOLUTION DEFINED

The shape of waveforms transmitted to CMOS depends on workpiece material and surface conditions. Before, stability also differed because the same setting was used on different workpiece. The Super-Resolution Algorithm identifies the width of waveforms and automatically performs the setting best suited for the shape of waveforms.

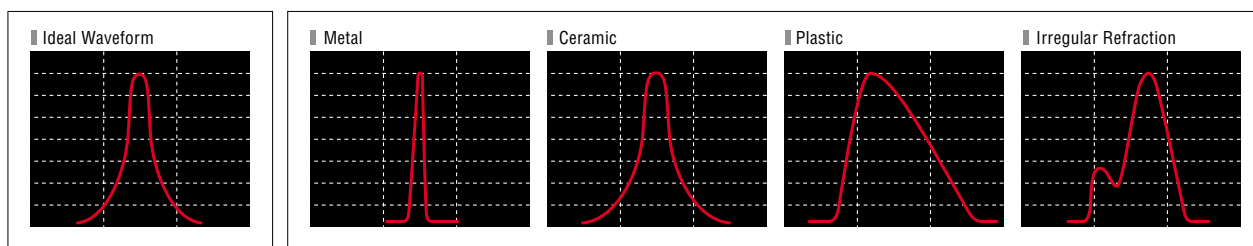

SCAN Function with Wide Dynamic Range

SCAN (=Sensitive-laser Control Analyser)

The laser power, shutter time and reception gain on this device are adjust in real-time in order to deliver stable detection faithfully for all targets. We also developed a new digital circuit that enables a dynamic range of x1.5 million, 2.5 times higher than past models. Real-time controls that suit targets and their surface conditions enable stable detection.

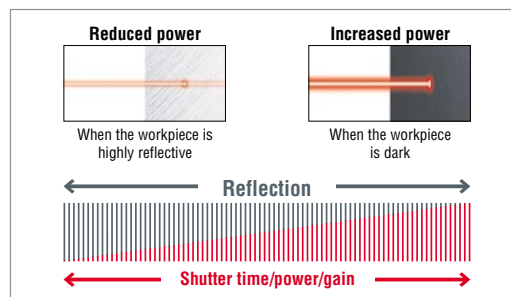

Sharp-Line Beam

KEYENCE's original optical system pushes the beam diameter to the limits (25 μm), and its sharpness enables the most excellent stability in history. We have overhauled and optimised our optical system for spot profiling for stability in applications that, until now, yielded very erratic results.

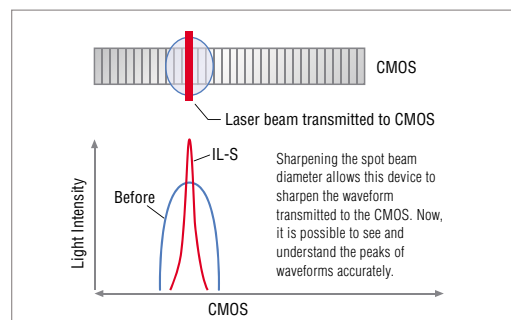

APPLICATION



Measuring the height of a chip after bonding

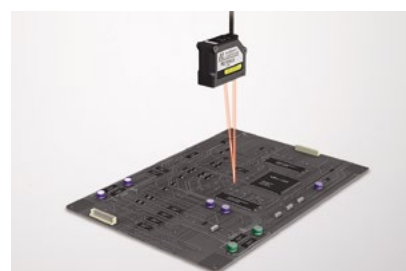

Height controls of a PC board

KEYENCE Lineup of Heads for Varied Applications (20 mm to 1,000 mm)

IL Wide Range of Sensor Heads

IL-030

Reference distance 30 mm
Measurement range 20 to 45 mm
Display Resolution 1 μ m
Repeatability 1 μ m

IL-065

Reference distance 65 mm
Measurement range 55 to 105 mm
Display Resolution 2 μ m
Repeatability 2 μ m

IL-100

Reference distance 100 mm
Measurement range 75 to 130 mm
Display Resolution 2 μ m
Repeatability 4 μ m



Repeatability 1 μ m

Dynamic Range (x1 million)

IL-300

Reference distance 300 mm
 Measurement range 160 to 450 mm
 Display Resolution 10 μm
 Repeatability 30 μm

IL-600

Reference distance 600 mm
 Measurement range 200 to 1000 mm
 Display Resolution 50 μm
 Repeatability 50 μm



Max. 1m

SCAN Function with Wide Dynamic Range

SCAN (= Sensitive-laser Control Analyser)

The laser power, shutter time and reception gain (gain) on this device adjust in real-time in order to deliver stable detection faithfully for all targets. We also developed a new digital circuit that enables a dynamic range of x1 million, 1.7 times higher than past models. Real-time controls that suit targets and their surface conditions enable stable detection.

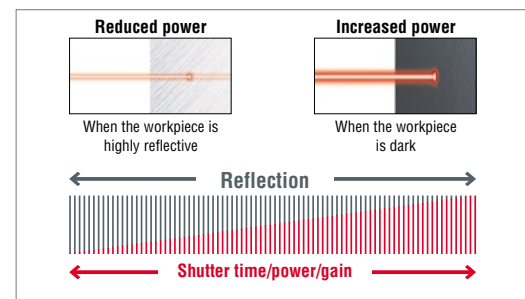

Rugged Head Structure

The head structure was redesigned to make it rugged enough to withstand almost any environment. In addition, the housing is made of die cast SUS304 for added strength and protection.



Die cast metal used for IP67/optical base

The IL Series has achieved the smallest head housing in its class by adopting the unique aspherical lens. The weight of the head is a mere 60g*. *IL-030

The multi-function amplifier

Calculation Function

Addition mode

SETTING EXAMPLE 1
(thickness measurement)



SETTING EXAMPLE 2
(width measurement)

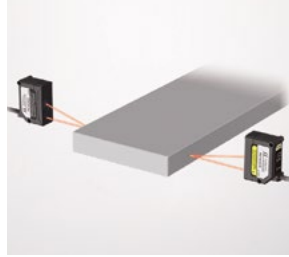

Subtraction mode

SETTING EXAMPLE 1
(Measurement of height difference)



SETTING EXAMPLE 2
(Measuring tilt)



Internal calculations are possible for all kinds of applications.

This device is equipped with an all-in-one add/subtract function that focuses PLC data and reduces programming hours.

NEW MODE – Thickness Calibration Function Included

3-step easy calibration

With conventional devices, calibration had to be conducted on every individual sensor head, however, the IL Series has a dedicated mode that allows calibration to be completed in 3 simple steps.

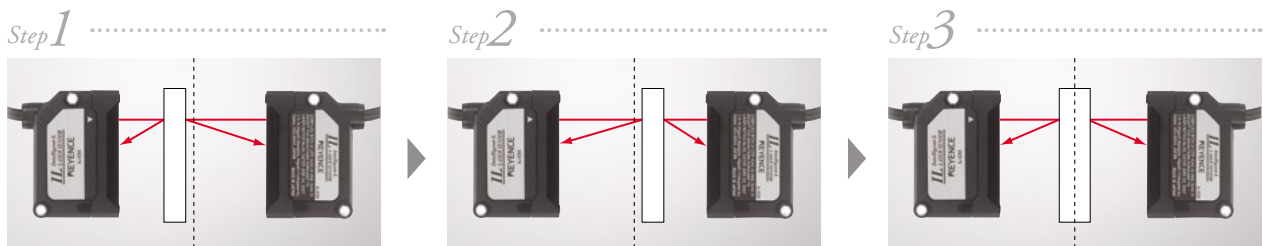

Step 1
Bring the target close to one sensor head and input the thickness data, then push the set button.

Step 2
Bring the same target used in Step 1 close to the opposing sensor head and push the set button.

Step 3
Insert a target thicker than the target used in Step 2. Input the thickness data. Then pushing the set button completes calibration.

When bringing the target closer to the sensor head in Steps 1 and 2, you are compensating for the misalignments that occur during installation. To set, you can begin with either one of the sensor heads.

Height difference count filter function included

This function identifies step edges automatically and delivers one-shot output for each step. Create settings for count and seam detection applications easily, without the programming hours.

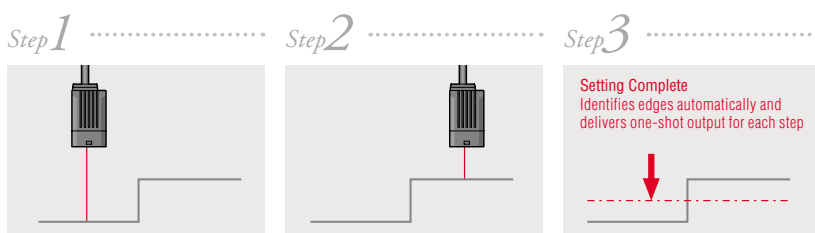

Press the SET button for the lower step.

Press the SET button for the upper step.

Setting Complete
Identifies edges automatically and delivers one-shot output for each step

Intermediary value threshold entered automatically.

Count the number of sheets of printed material

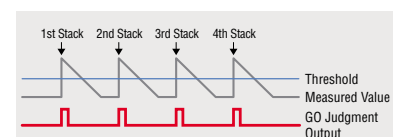
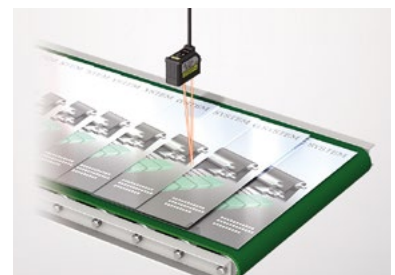

High pass filter function included

This function displays frequencies above the adjustable cutoff frequency and ignores changes below that cutoff. It is effective for discarding smooth fluctuations and looking only at rapid changes.

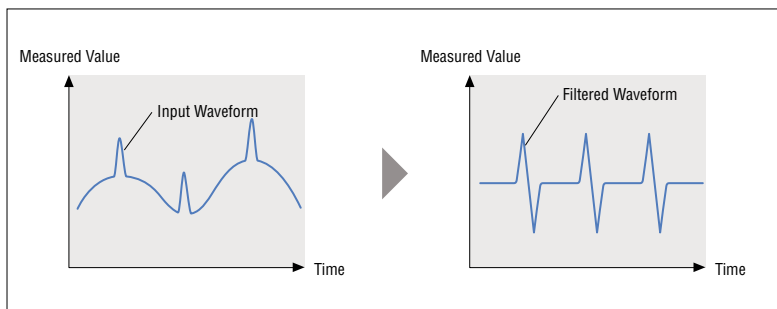

Detection on the edge of a sheet



Ambient light elimination function included

In order to counteract any ambient light interference, the IL Series automatically activates the ambient light elimination function when the sampling cycle is set to '2 ms' or '5 ms', reducing the effects of ambient light.

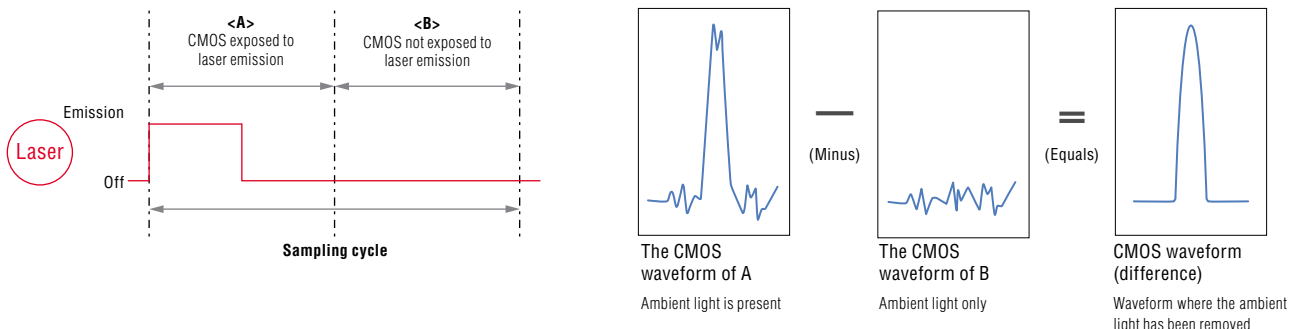

Function Choices

NPN/PNP Output Selection (judgment selection)

Both NPN and PNP outputs are supported. The outputs are set the first time the user turns on the power. These settings can subsequently be changed. Judgments are output as HIGH, GO, or LOW.

Analogue Output Selection

The following five types of analogue outputs can be selected. The output is selected the first time the user turns on the power.

Setting value	Description
OFF	No output
0-5V	Analogue output after the judgment value is converted to the range from 0 to 5 V.
-5-5V	Analogue output after the judgment value is converted to the range of ± 5 V.
1-5V	Analogue output after the judgment value is converted to the range from 1 to 5 V.
4-20mA	Analogue output after the judgment value is converted to the range from 4 to 20 mA.

The setting can be changed.

Bank Function

The bank function can register up to four patterns of specific settings.* For example, in response to a measurement target changeover, this function allows the user to easily switch between the patterns of registered settings.

* HIGH setting value, LOW setting value, shift value, analogue output scaling setting

Mounting method options

Both panel and DIN-rail mount units are available.



IL-1500/1550
Panel mount type



IL-1000/1050
DIN-rail mount type

Variety of heads enables abundance of applications

POSITIONING

Robot arm positioning



Detect robot arm chuck precision on the X-, Y- and Z-axes. The long range head enables detection from long distances.

Vision system CCD height positioning



Position the vision system on the Z-axis during substrate inspection. This device delivers stable detection, even for different target workpiece materials.

Roll chuck position detection

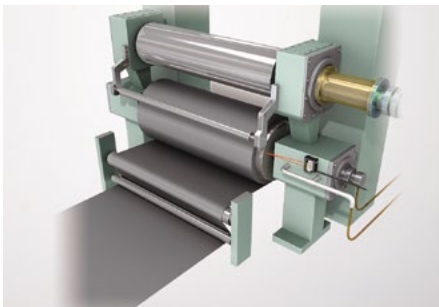

Detect the position of roll chucks for film winding. Save a huge amount of adjustment time, even for different equipment.

Cutting machine workpiece positioning

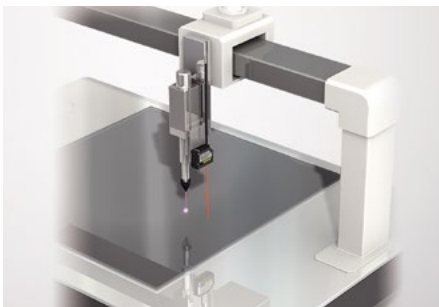

Detect torch heights when cutting steel plates. This device enables stable detection, even for different workpiece material.

THICKNESS

Press processing thickness differentiation



Differentiate between steel plates or catch two sheets going through at once with thickness differentiation in the press process. The long range head enables differentiation from long distances, even for large-sized pressing.

Thickness/width measurements of building material boards

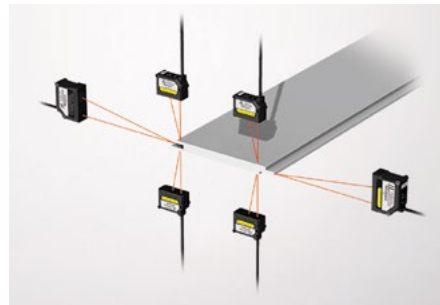

Thickness and width can be simultaneously measured immediately after the extrusion process. In addition, man-hours for setup and product changeovers are reduced using the thickness calibration function.

Single/double-sheet substrate differentiation

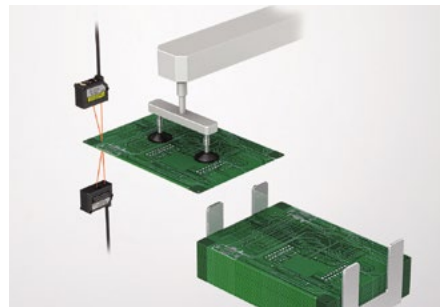

Differentiate single/double sheets when transferring substrates. This device enables stable detection, even for different substrate material.

Sheet material thickness detection

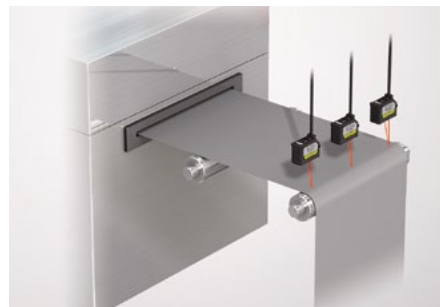

This device constantly monitors thickness differentiation of sheet material. The multi-point head allows you to detect irregularities in the thickness of edges and in the bodies of materials.

SEAM/COUNT

Rubber sheet seam detection

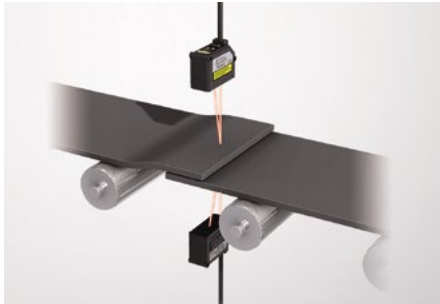

Detect seams in rubber sheets. Sensors above and below the workpieces enable stable detection, even when the sheets flip-flop.

Detecting welding seams



Detect welding seams on steel plates. The Height Difference Count Filter Function enables stable detection.

Stacker counting & uneven checks

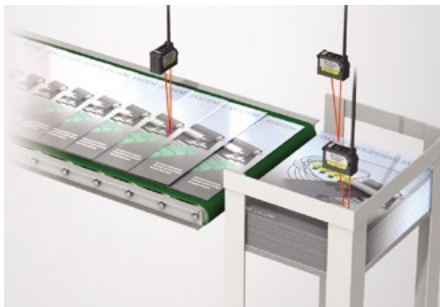

The IL Series counts how many items are being transported along a conveyor, in addition to the non-contact detection of uneven stacking in the stacker. Reliable detection regardless of colour changes in the targets.

Counting air conditioner filter sheets

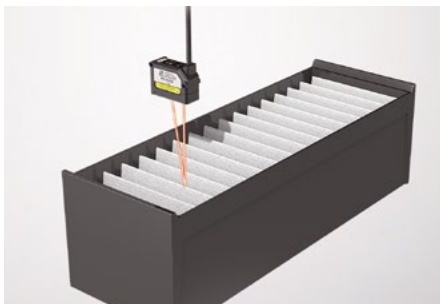

Count the number of air conditioner filter sheets. The High Pass Filter Function enables stable detection, even for workpiece whose height is not constant.

HEIGHT

Detection of stage inclination prior to furnace transportation

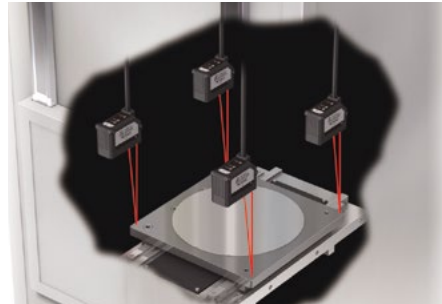

Calculates the inclination by measuring multiple points on the stage prior to transferring to the furnace. Transferring the product after correcting the inclination allows for consistent temperature control.

Liquid level detection in a tank of chocolate



This device constantly monitors the level of liquid surfaces without contacting the liquid. Using a long range head makes it possible to detect levels from far away, even in tight spaces.

Differentiation of different types of plastic components

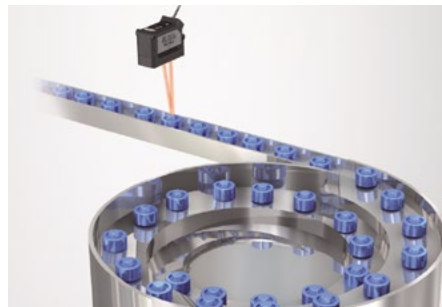

Reliable differentiation, even in highly variable small parts, using a high-precision sensor head. Even when the variety changes, external changeover of up to 4 patterns is possible by setting items in the bank function.

Double-chip prevention/
chip presence detection

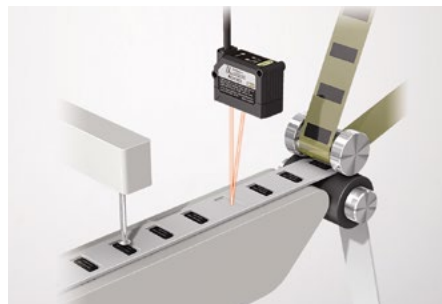

Check whether chips are present or not, or if two are present by mistake during chip transfer. This device enables stable detection, even during high-speed transfers.

Variety of heads enables abundance of applications

CONTROL

Control marking height



Control the distance between the head of marking instruments and workpiece. This device enables stable detection, even for different target workpiece.

Control sheet roll diameter



Control feed speed and tension rolling with constant monitoring of sheet diameter during rolling and unrolling processes.

Control welding torch height

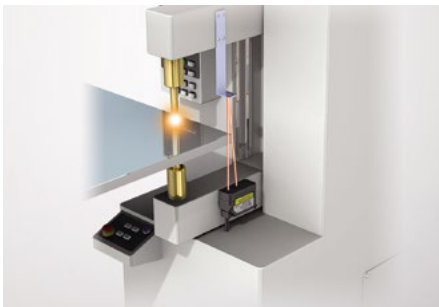

Control the height of welding torches. Boost welding precision through constant, exhaustive monitoring.

Height controls of a hoop material

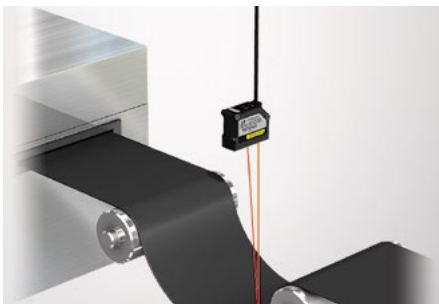

By using a long range head type of sensor range head, it is possible to control height of hoop materials such as steel plates and sheet materials even during transportation. The sensor head can be installed at a distance of up to 1000 mm.

SHAPE-WARP

Warpage detection in ceramic boards

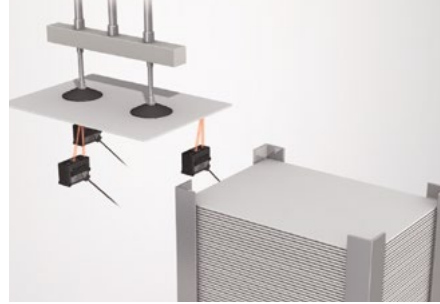

As the sensor head is compact, multiple point measurements of small-scale boards are possible. By calculating the measurement data externally, simultaneous measurements of positioning and warpage are possible.

Detect H-beam flange warp

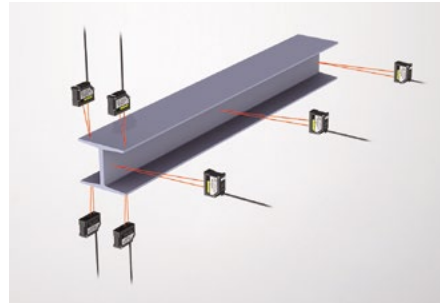

Detect the warp of H-beam flanges at multiple points before using a correction mechanism. Use a long range head for compatibility with many different kinds of workpiece.

STROKE/VIBRATION

Press stroke control

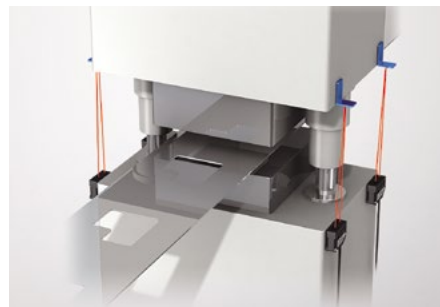

Proactively prevent press defects by constantly monitoring the amount of press strokes and the bottom dead centre of presses. Use a long range head to enable compatibility with large-sized pressing machine.

Traverser stroke control

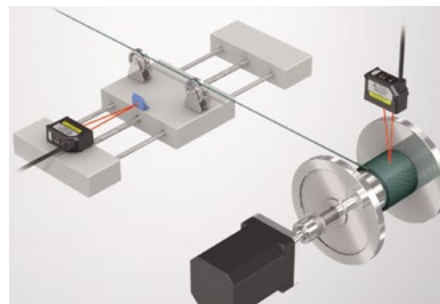

Prevent rolling disorders by controlling traverser strokes while measuring the amount that bobbins roll to provide feedback to the instrument.

OPTIONAL LINEUP

Communication Unit Variations

Communication method	Model	Appearance	Judgement result readout	Measurement value readout	Control input	Modify tolerance value	Remarks
Ethernet (TCP/IP)	DL-EN1		○	○	○	○	Uses TCP/IP communication. Communicate by creating a communication program.
EtherCAT®	DL-EC1A		◎	◎	◎	○	Uses cyclic communication. A communication program does not need to be created. Change settings using mail box communication.
EtherNet/IP®	DL-EP1		◎	◎	◎	○	Uses cyclic communication. A communication program does not need to be created. Change settings using explicit message communication.
PROFINET	DL-PN1		◎	◎	◎	○	Uses data I/O communication. A communication program does not need to be created. Change settings using record data communication.
PROFIBUS	DL-PD1		◎	◎	◎	○	Uses cyclic transmissions. A communication program does not need to be created. Change settings using the DP-V1 service.
DeviceNet®	DL-DN1		◎	◎	◎	◎	Uses I/O communication. A communication program does not need to be created. Change settings using explicit message communication.
CC-Link	DL-CL1		◎	◎	◎	◎	Uses cyclic transmissions. A communication program does not need to be created. Change settings using handshake control.
RS-232C	DL-RS1A		○	○	○	○	Uses RS-232C communication. Communicate by creating a communication program.

The ◎ symbol indicates wire savings and communication program creation is not required. ○=Can be accessed by creating a communication program. ×=Cannot be accessed. EtherCAT® is registered trademark and patented technology, licensed by Beckhoff Automation GmbH, Germany.

Sensor head cables (sold separately)

The cable does not come attached with the sensor head and must be purchased separately.

Appearance	Cable length	Model	Weight
1 cable included 	2 m	OP-87056	Approx. 80 g
	5 m	OP-87057	Approx. 190 g
	10 m	OP-87058	Approx. 360 g
	20 m	OP-87059	Approx. 680 g

This connector is required if the cable is cut.



Connector used to connect to a display unit (2 pcs.)

OP-84338

SPECIFICATIONS



Sensor heads

Model	IL-S025	IL-S065
Reference distance	25 mm	65 mm
Measurement range	20 to 30 mm	55 to 75 mm
Light source	Red semiconductor laser, wavelength: 655 nm (visible light)	
	Laser class	Class 2 (FDA (CDRH) Part1040.10) ¹ Class 2 (IEC 60825-1)
	Output	560 μW
Spot diameter (at standard distance)	Approx. 25×1200μm	Approx. 55×1700μm
Linearity ^{2,3}	±0.075% of F.S.(20 to 25 mm) ±0.1% of F.S.(20 to 30 mm)	±0.05% of F.S.(55 to 65 mm) ±0.075% of F.S.(55 to 75 mm)
Repeatability ⁴	1 μm	2 μm
Sampling rate	0.33/1/2/5 ms (4 levels available)	
Operation status indicators	Laser emission warning indicator: Green LED, Analogue range indicator: Orange LED, Reference distance indicator: Red/Green LED	
Temperature characteristics ³	0.03% of F.S./°C	0.02% of F.S./°C
Environmental resistance	Enclosure rating	IP67
	Ambient light ⁵	Incandescent lamp: 10000 lux
	Ambient temperature	-10 to +50°C (No condensation or freezing)
	Relative humidity	35 to 85% RH (No condensation)
	Vibration	10 to 55 Hz Double amplitude 1.5 mm XYZ each axis: 2 hours
Pollution degree	3	
Material	Housing material: PBT, Metal parts: SUS304, Packing: NBR, Lens cover: Glass, Cable: PVC	
Weight	Approx. 60g	Approx. 75g

- The laser classification for FDA (CDRH) is implemented based on IEC 60825-1 in accordance with the requirements of Laser Notice No.50.
- Value when measuring the KEYENCE standard target (white diffuse object).
- F.S. of each model is as follows. IL-S025: ±5 mm IL-S065: ±10 mm
- Value when measuring the KEYENCE standard target (white diffuse object) at the reference distance, sampling rate: 1 ms, and average number of times: 128.
- Value when the sampling rate is set to 2 ms or 5 ms.



Sensor heads

Model	IL-030	IL-065	IL-100	IL-300	IL-600
Reference distance	30 mm	65 mm	100 mm	300 mm	600 mm
Measurement range	20 to 45 mm	55 to 105 mm	75 to 130 mm	160 to 450 mm	200 to 1000 mm
Light source	Red semiconductor laser, wavelength: 655 nm (visible light)				
	Laser class	Class 1 (FDA (CDRH) Part1040.10) ¹ Class 1 (IEC 60825-1)	Class 2 (FDA (CDRH) Part1040.10) ¹ Class 2 (IEC 60825-1)		
	Output	220 μW	560 μW		
Spot diameter (at standard distance)	Approx. 200 × 750 μm	Approx. 550 × 1750 μm	Approx. 400 × 1350 μm	Approx. ø0.5 mm	Approx. ø1.6 mm
Linearity ^{2,3}	±0.1% of F.S. (25 mm to 35 mm)	±0.1% of F.S. (55 mm to 75 mm)	±0.15% of F.S. (80 mm to 120 mm)	±0.25% of F.S. (160 mm to 440 mm)	±0.25% of F.S.(200 to 600 mm) ±0.5% of F.S.(200 to 1000 mm)
Repeatability ⁴	1 μm	2 μm	4 μm	30 μm	50 μm
Sampling rate	0.33/1/2/5 ms (4 levels available)				
Operation status indicators	Laser emission warning indicator: Green LED, Analogue range indicator: Orange LED, Reference distance indicator: Red/Green LED				
Temperature characteristics ³	0.05% of F.S./°C	0.06% of F.S./°C	0.06% of F.S./°C	0.08% of F.S./°C	
Environmental resistance	Enclosure rating	IP67			
	Ambient light ⁵	Incandescent lamp: 5000 lux	Incandescent lamp: 7500 lux	Incandescent lamp: 5000 lux	
	Ambient temperature	-10 to +50°C (No condensation or freezing)			
	Relative humidity	35 to 85% RH (No condensation)			
	Vibration	10 to 55 Hz Double amplitude 1.5 mm XYZ each axis: 2 hours			
Pollution degree	3				
Material	Housing material: PBT, Metal parts: SUS304, Packing: NBR, Lens cover: Glass, Cable: PVC				
Weight	Approx. 60g	Approx. 75g	Approx. 135g		

- The laser classification for FDA (CDRH) is implemented based on IEC 60825-1 in accordance with the requirements of Laser Notice No.50.
- Value when measuring the KEYENCE standard target (white diffuse object).
- F.S. of each model is as follows. IL-030: ±5 mm IL-065: ±10 mm IL-100: ±20 mm IL-300: ±140 mm IL-600: ±400 mm
- Value when measuring the KEYENCE standard target (white diffuse object) at the reference distance, sampling rate: 1 ms, and average number of times: 128. For the IL-300/IL-600, the sampling rate is 2 ms.
- Value when the sampling rate is set to 2 ms or 5 ms.

DIMENSIONS

Unit : mm

Sensor heads

IL-S025/IL-030

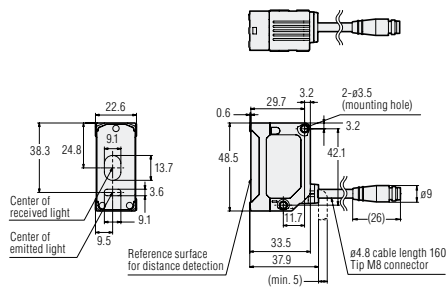

Mounting bracket (supplied)

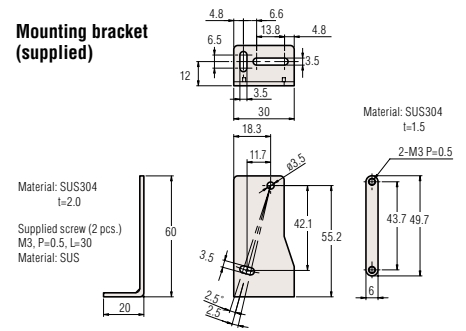

IL-S065/IL-065/100

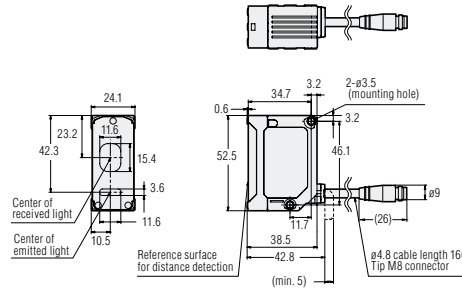

Mounting bracket (supplied)

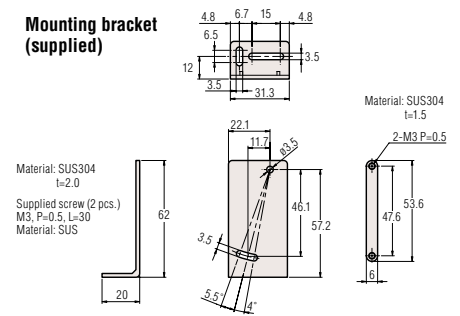

IL-300/600

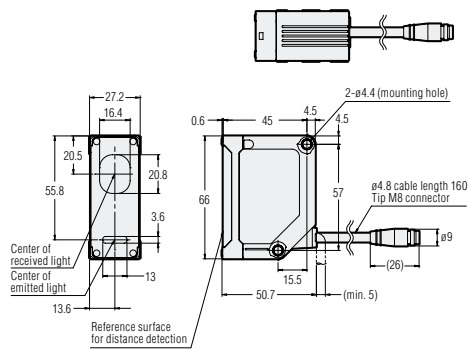

Mounting bracket (supplied)

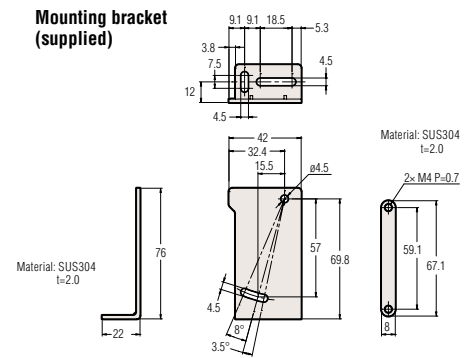

SPECIFICATIONS

Amplifier unit

Model	IL-1000	IL-1500	IL-1050	IL-1550
Type	DIN-rail mount	Panel mount	DIN-rail mount	Panel mount
Main unit/expansion unit	Main unit		Expansion unit	
Head compatibility	Compatible			
Display	Minimum displayable unit	IL-S025/IL-030: 1 μm, IL-S065/IL-065/IL-100: 2 μm, IL-300: 10 μm, IL-600: 50 μm		
	Display range	IL-S025/IL-030/IL-S065/IL-065/IL-100: ±99.999 mm to ±99 mm (4 levels selectable), IL-300/IL-600: ±999.99 mm to ±999 mm (3 levels selectable)		
	Display rate	Approx. 10 times/sec.		
Analogue voltage output ¹	±5 V, 1 to 5 V, 0 to 5 V Output impedance 100 Ω		None	
Analogue current output ¹	4 to 20 mA Maximum load resistance of 350 Ω			
Control input ²	Bank switch input	Non-voltage input		
	Zero-shift input			
	Stop emission input			
	Timing input			
	Reset input			
Control output ³	Judgment output	Open collector output (NPN, PNP changeover possible/N.O., N.C. changeover possible)		
	Alarm output	Open collector output (NPN, PNP changeover possible/N.C.)		
Current	Power voltage ⁴	10 to 30 VDC ripple (P-P) 10% included, Class 2		Supplied by main unit
	Power consumption	2300 mW or less (at 30 V: 77 mA or less)	2500 mW or less (at 30 V: 84 mA or less)	2000 mW or less (at 30 V: 67 mA or less) 2200 mW or less (at 30 V: 74 mA or less)
Environmental resistance	Ambient humidity	-10 to +50°C (No condensation or freezing)		
	Ambient temperature	35 to 85% RH (No condensation)		
	Vibration	10 to 55 Hz Double amplitude 1.5 mm XYZ each axis: 2 hours		
	Pollution degree	2		
Material	Case / Front sheet: Polycarbonate; Key tops: Polyacetal; Cable: PVC			
Weight (including attachments)	Approx. 150g	Approx. 170g	Approx. 140g	Approx. 160g

1. Select and use one of ±5 V, 1 to 5 V, 0 to 5 V or 4 to 20 mA.

2. Assign an input of your choice to the 4 external input lines before using.

3. - The NPN open collector rated output is: 50 mA max./ch (20 mA when adding an expansion unit) less than 30 V, residual voltage less than 1 V (less than 1.5 V when adding over 6 units including the main unit)

- The PNP open collector rated output is: 50 mA max./ch (20 mA/ch when adding expansion units), less than power voltage, and less than 2 V residual voltage (less than 2.5 V when adding over 6 units including the main unit)

4. If there are over 6 additional expansion units, please use a power voltage of 20 to 30 V.

DIMENSIONS

Unit : mm

Amplifier unit (DIN-rail mount type) IL-1000/IL-1050

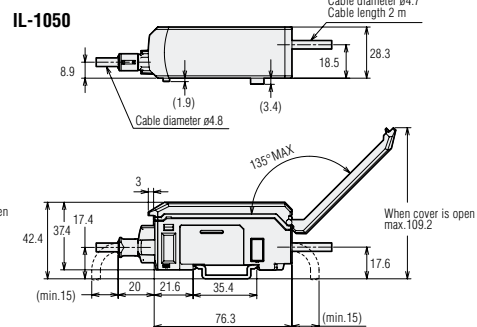
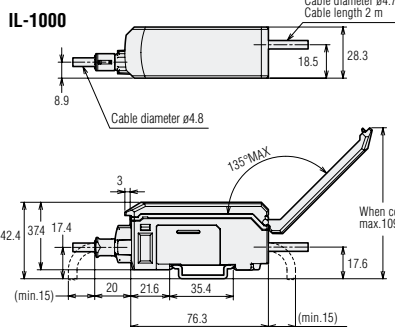

Amplifier unit (Panel mount type) IL-1500/IL-1550

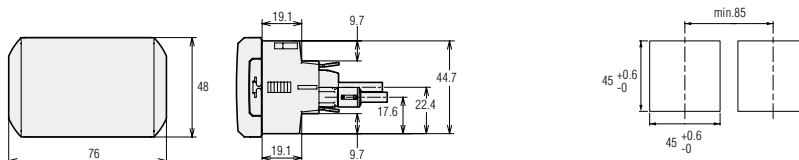
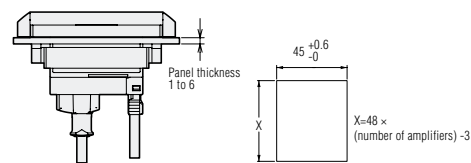
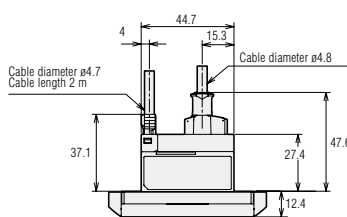

WIRING DIAGRAM

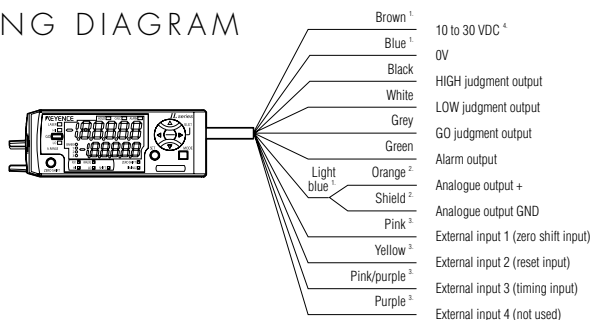

1. The brown, blue, and light blue cables are not provided in a IL-1050/IL-1550 unit (expansion unit).

The power is supplied to the expansion unit from the IL-1000/IL-1500 unit (main unit).

2. For an analogue output, OFF (not used), 0 to 5 V, ±5 V, 1 to 5 V, or 4 to 20 mA can be selected.

3. For an external input, bank A input, bank B input, laser emission stop input, or OFF (not used) can also be selected.

For details, refer to the User's Manual.

4. If there are over 6 additional expansion units, please use a power voltage of 20 to 30 V.

EtherCAT® Network communication unit DL-EC1A

Model		DL-EC1A
EtherCAT® Specifications	Compatible functions	Process data object communication (cyclic communication) Mailbox communication (message communication) CoE compatible
	Conformance test	Complies with V2.0.42

PROFINET Network communication unit DL-PN1

Model		DL-PN1
PROFINET specifications	Device type	Data I/O Communication
	Number of connections	Record data Communication
	Update time	1
	GSDML Version	2 to 512 ms
	Conformance class	Ver. 2.3
	Conformance test	Conformance Class A
	Compliant protocol	V2.2.4 LLDP, DCP

PROFIBUS DP Network communication unit DL-PD1

Model		DL-PD1
PROFIBUS DP specifications	Device type	DP-V1 Slave (D-sub 9 pin, Number of the ports: 1)
	Communication speed	9.6 kbps to 12 Mbps
	Cable length	9.6 / 19.2 / 45.45 / 93.75 kbps : 1200 m 187.5 kbps : 1000 m, 500 kbps : 400 m 1.5 Mbps : 200 m, 3 / 6 / 12 Mbps : 100 m

EtherNet/IP® Network communication unit DL-EP1

Model		DL-EP1
EtherNet/IP® Specifications	Compatible Functions	Cyclic Communication Message communication (Explicit messaging) Compatible with UCMM and Class 3
	Number of connections	64
	RPI (Transmission cycle)	0.5 to 10000 ms (0.5 ms unit)
	Tolerable communication bandwidth for cyclic communication	6000 pps
	Conformance Test	Compatible with Version A7

DeviceNet® communication unit DL-DN1

Model		DL-DN1		
DeviceNet® Specifications	Compatible functions	Input/Output communication (poll)/ Explicit Message Communication		
	Address Settings	0 to 63 (PGM compatible)		
	Communication speed (Automatic switching method)	500 kbps	250 kbps	125 kbps
	Maximum cable length	100 m (thick cable)	250 m (thick cable)	500 m (thick cable)
		100 m (thin cable)	100 m (thin cable)	100 m (thin cable)
Network power source	11 to 25 VDC (DeviceNet® provided from the communication power source)			

CC-Link Network communication unit DL-CL1

Model		DL-CL1
CC-Link specifications	Compatible versions	Ver. 2.00 / Ver. 1.10 (selectable)
	Number of occupied stations	Ver. 2.00: 1 station, 8x / 2 stations, 8x / 4 stations, 2x; (selectable) Ver. 1.10: 1 / 2 / 4 stations (selectable)
	Type of station	Remote device station
	Transmission rate	156 kbps / 625 kbps / 2.5 Mbps / 5 Mbps / 10 Mbps
	Setting of station numbers	1 to 64

TCP/IP Network communication unit DL-EN1

Model		DL-EN1
Ethernet Specifications	Transmission rate	100Mbps (100BASE-TX)
	Transmission medium	STP cable or Category 5 or higher UTP cable (100BASE-TX)
	Maximum cable length	100 m (Distance between DL-EN1 and Ethernet switch)
Performance specifications	Socket communication, no-protocol commands, ASCII	TCP socket 1

RS-232C Network communication unit DL-RS1A

Model		DL-RS1A
RS-232C Specifications	Communication Method	Full duplex
	Synchronization Method	Start-stop
	Transmission Code	ASCII
	Baud rate	2400/4800/9600/19200/38400 bps

DIMENSIONS

Unit : mm

DL-EC1A

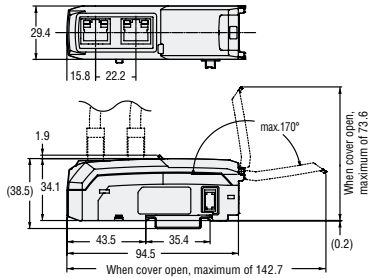

DL-PD1

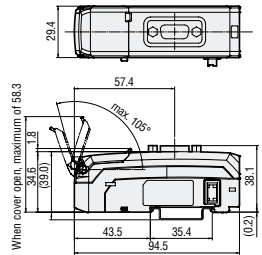

DL-PN1/EP1/EN1

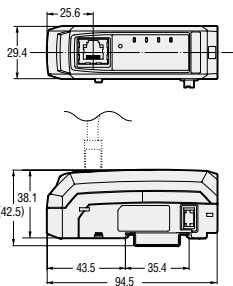

DL-DN1

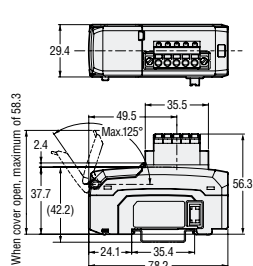

DL-RS1A

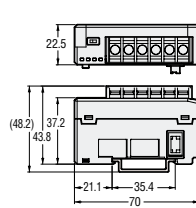

DL-CL1

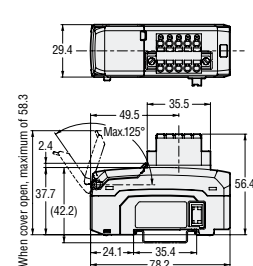

KEYENCE VALUE



Since 1974, KEYENCE has steadily grown and innovated to become a world leader in the development of automation and quality assurance solutions

Direct Sales Network

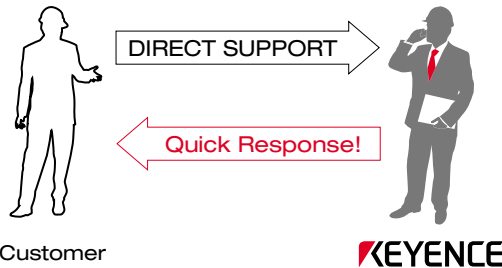

Your Sales Engineer

- || Local
- || Specialized Product Expert
- || KEYENCE Direct

Direct Support

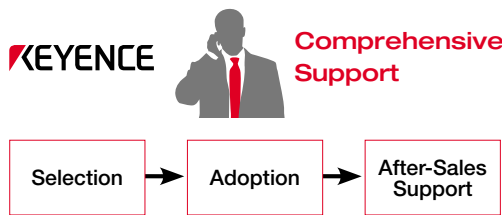

All From KEYENCE

- || On-Site Product Demonstrations
- || Application Sample Testing
- || Direct Phone & On-Site Support

Same-Day Shipping

With most items in stock, received orders can ship the same day, reducing your overhead costs and losses due to work stoppage.

KEYENCE CORPORATION

GLOBAL NETWORK CONTACT YOUR NEAREST OFFICE FOR RELEASE STATUS							
AUSTRIA +43 (0)2236 378266 0	CHINA +86-21-5058-6228	HONG KONG +852-3104-1010	ITALY +39-02-6688220	MEXICO +52-55-8850-0100	ROMANIA +40 (0)269 232 808	SWITZERLAND +41 (0)43 455 77 30	USA +1-201-930-0100
BELGIUM +32 (0)15 281 222	CZECH REPUBLIC +420 220 184 700	HUNGARY +36 1 802 7360	JAPAN +81-6-6379-2211	NETHERLANDS +31 (0)40 206 6100	SINGAPORE +65-6392-1011	TAIWAN +886-2-2721-1080	VIETNAM +84-24-3772-5555
BRAZIL +55-11-3045-4011	FRANCE +33 1 56 37 78 00	INDIA +91-44-4963-0900	KOREA +82-31-789-4300	PHILIPPINES +63-(0)2-8981-5000	SLOVAKIA +421 (0)2 5939 6461	THAILAND +66-2-078-1090	
CANADA +1-905-366-7655	GERMANY +49-6102-3689-0	INDONESIA +62-21-2966-0120	MALAYSIA +60-3-7883-2211	POLAND +48 71 368 61 60	SLOVENIA +386 (0)1 4701 666	UK & IRELAND +44 (0)1908-696-900	