



High-Accuracy Digital Contact Sensor  
GT2 Series



EtherNet/IP™ DeviceNet™



Unsurpassed  
Accuracy  
and  
Durability



*Air push type  
Debut!!*

*Intelligent sensor  
I-SERIES*

GT2 Series

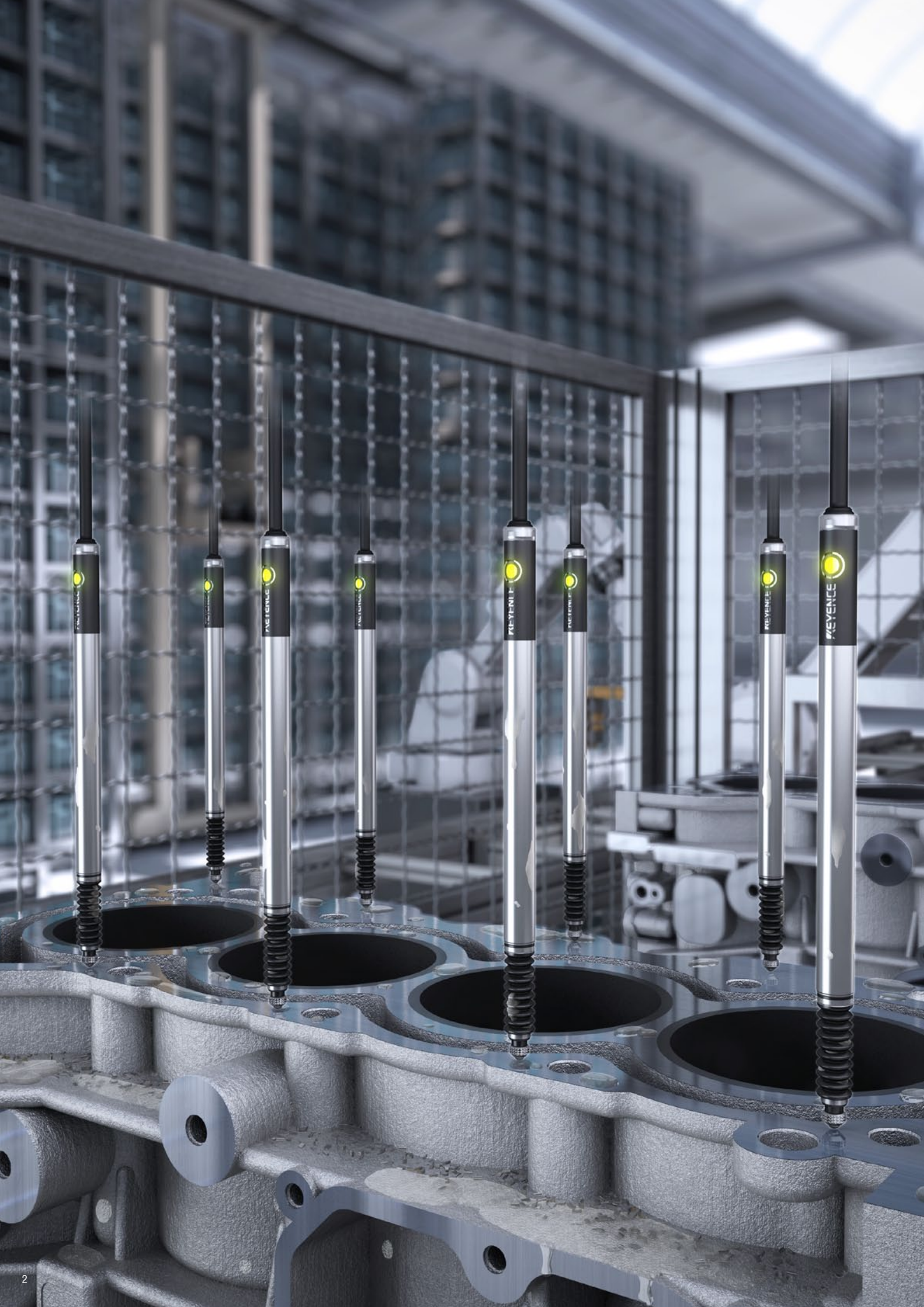

## SCALE SHOT SYSTEM II

Display resolution 0.1 $\mu\text{m}$
--------------------------------------

Accuracy 1 $\mu\text{m}$
--------------------------

The  $\varnothing 8$  mm sensor head is equipped with KEYENCE's proprietary Scale Shot System II, which allows it to achieve the highest accuracy in its class throughout its entire measurement range. It also overcomes the disadvantages of conventional methods such as tracking errors and not knowing absolute position.

## TOUGH & RUGGED CONSTRUCTION

NEMA Type 13/IP67G
--------------------

100 million cycles detecting durability
---

PUR cable
-----------

Complies with NEMA Type 13/IP67G oil resistance protection standards. These sensor heads can be used in wet and dusty environments, and now even in environments with splashing oil. The sensor head also clears a detecting durability of 100 million cycles with its long lasting linear ball bearings.

## MULTI-SENSOR UNIT

5 heads can connect to 1 amplifier unit
---

A multi-sensor amplifier unit has been added to our line up which allows up to 5 sensor heads to connect to 1 amplifier unit. A maximum of 3 amplifier units and 15 sensor heads can be simultaneously connected to support multi-point applications. Also, larger systems can easily be constructed using the communication units.

## Scale Shot System II:

A new detection principle completely free of tracking errors

The absolute value scale, with different slit patterns engraved according to position, is captured at high speed with a high-resolution CMOS sensor. This world's first detection principle delivers the highest accuracy in its class with no tracking errors during high-speed movement.

### Highest accuracy in its class

DISPLAY RESOLUTION

**0.1  $\mu\text{m}$**

ACCURACY

**1  $\mu\text{m}$**



CMOS sensor detects the position of the absolute value scale.

## PROBLEMS WITH CONVENTIONAL TYPES

### SCALE (PULSE-COUNT) METHOD

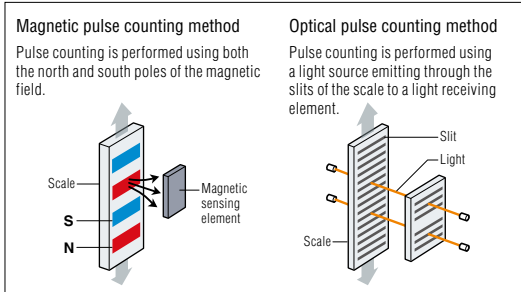

### DIFFERENTIAL TRANSFORMER METHOD

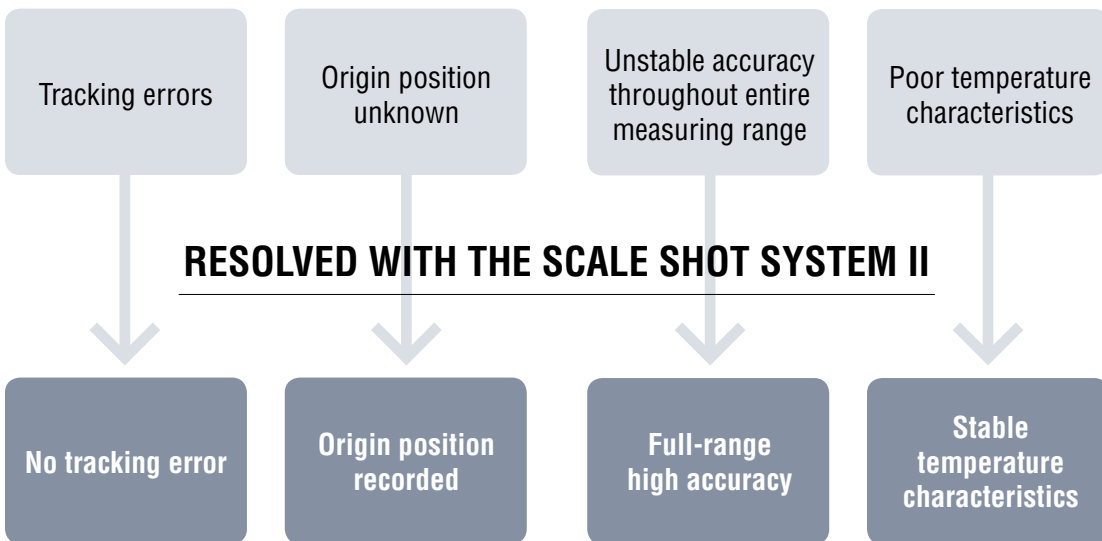
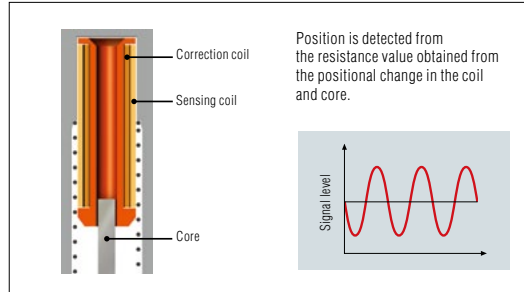

### Technology of the Scale Shot System II

This innovative system was created based on KEYENCE's newly developed technology. High-intensity illumination from HL-LEDs reliably emits light through the absolute value scale to a high resolution CMOS. Output signals are calculated by the I-Processor, which allows for constant position recognition. All these features are integrated into a slim 8-mm diameter body.

<b>HL-LED</b>	These newly developed point light source LEDs provide even, high-intensity illumination which is 9 times more intense than conventional models. *HL: High Luminance
<b>HIGH-RESOLUTION CMOS</b>	With high sensitivity, this imaging element receives the LED light that passes through the absolute value glass scale and generates output signals with resolution twice that of conventional models.
<b>I-PROCESSOR</b>	This customised IC is equipped with a new algorithm that performs high-speed, high-resolution calculation of the output signals transmitted from the CMOS sensor.

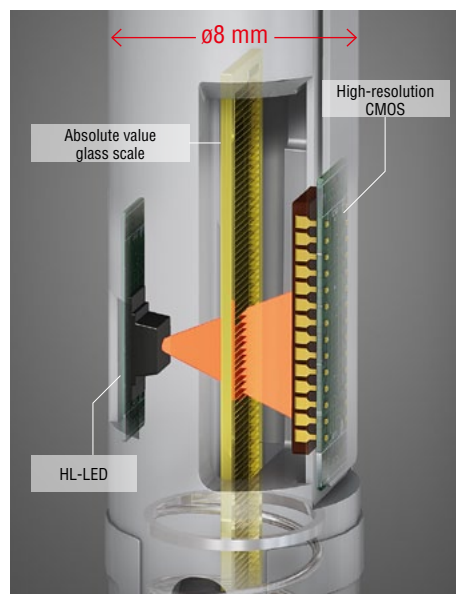

# USABLE IN OILY ENVIRONMENTS

\*GT2-P12K(F)/P12(F)

First in class

## NEMA Type 13/IP67G

The sensor head, including the connector and cable section, complies with two standards - NEMA Type 13 and IP67G. The sensor head can be mounted almost anywhere, even in environments with splashing water or oil.

### Oil-resistant connector and cable

Both the sensor head and connector comply with NEMA Type 13/IP67G. Extremely oil-resistant PUR (polyurethane) is used for the GT2-sensor cable to reduce the risk of oil penetration.

### Seamless construction

The sensor body is cast in one piece for seamless outer construction. Corrosion from water and oil is reduced due to the fully enclosed structure.

#### NEMA Type 13

NEMA (National Electrical Manufacturers Association) specifies the classification and description of enclosures for electrical equipment. The classification is represented as the "Type", and NEMA Type 13 is designed to provide a degree of protection against the ingress of oil.

#### IP67G

IP67G represents the enclosure rating for electronic devices as defined by the JIS (Japanese Industrial Standards). IP67G represents "IP67" as defined by the IEC (International Electrotechnical Commission) with "G" added for its oil resistance.



EXTRAORDINARY DETECTING DURABILITY

# 100 million cycles

\*GT2-P12K(L/F)/P12(L/F)

A detecting durability of 100 million cycles has been achieved by using new high-strength linear ball bearings in the spindle. This can greatly reduce maintenance costs and replacement efforts.

## ■ Long lasting linear ball bearings

The all stainless steel construction of the spindle structure (shaft & bearings) reduced the weight of the GT2. Through these weight savings, wear due to friction inside the spindle has been minimised. This has dramatically increased endurance.

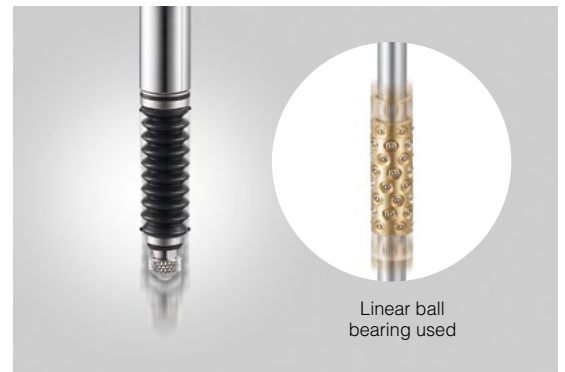

## FLEXIBLE FREE-CUT ROBOT CABLE & OIL-RESISTANT RELAY CONNECTOR

The cable between the relay connector and amplifier unit uses a flexible free-cut robot cable that withstands continuous bending. This allows the sensor to be installed on moving equipment. A detachable relay connector system is also used. This can greatly reduce replacement work during maintenance.

## ■ Flexible free-cut robot cable

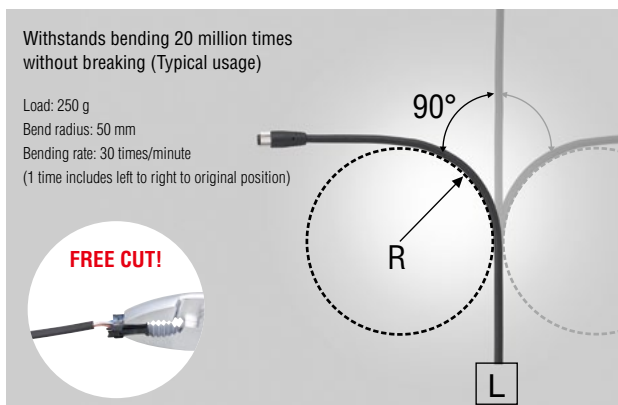

## ■ Detachable sensor head cable



## SAVE WIRING TIME WITH OPEN FIELD NETWORK SUPPORT

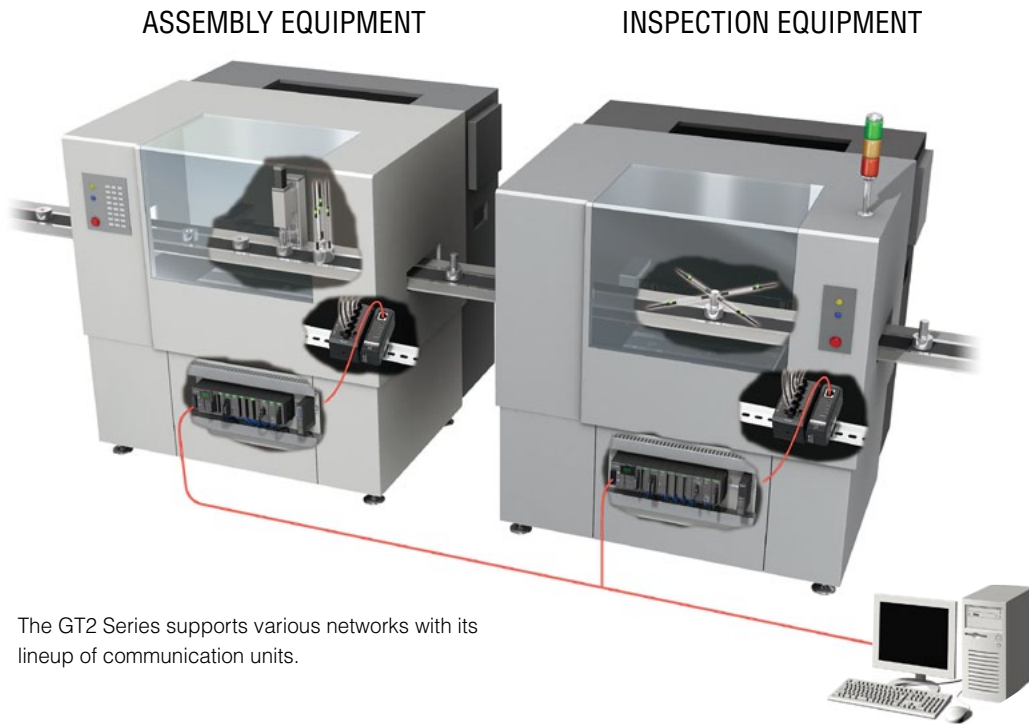

The GT2 Series supports various networks with its lineup of communication units.

### DL Series lineup

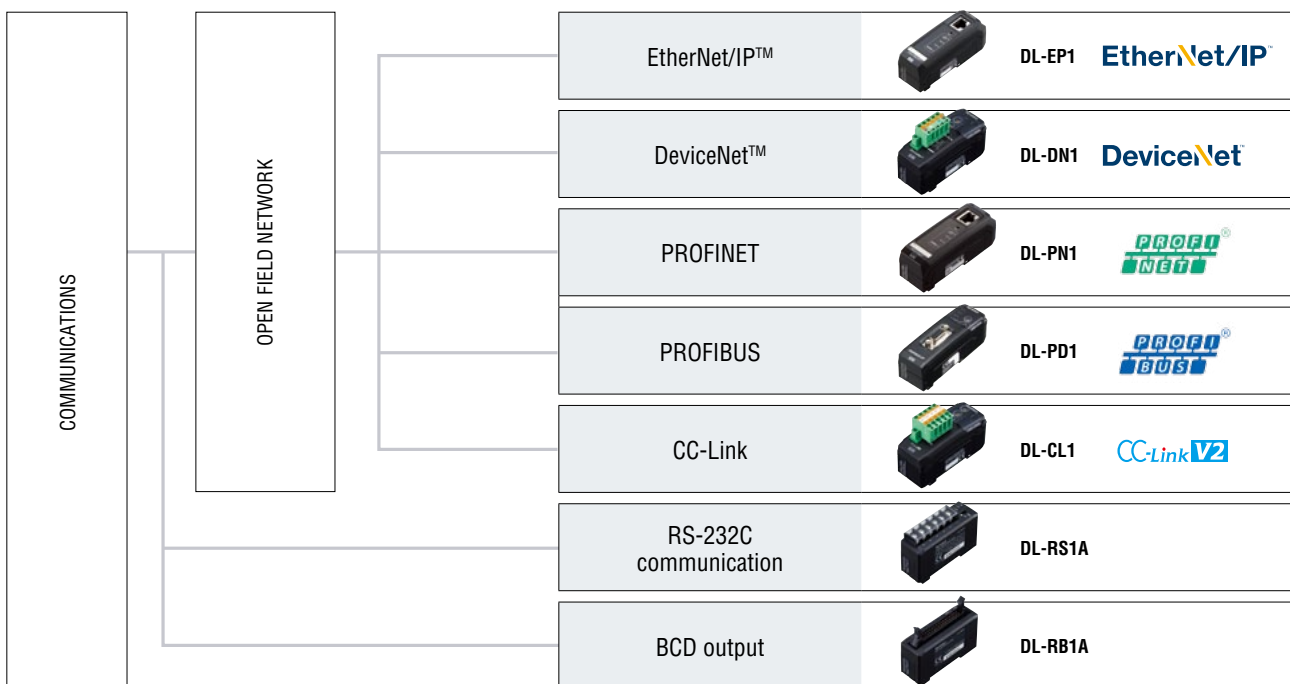

## ■ Batch read and change settings for multiple amplifier units

Batch transmit data for a maximum of 15 units.  
Settings can also be changed from a PC or PLC which leads to reduced setup time.



## ■ Further wiring and space savings with the multi-sensor unit

Up to 5 sensor heads can be connected to 1 multi-sensor amplifier unit. Up to 3 units can be linked, which allows for a maximum of 15 connected sensor heads.



## ■ Reduced wiring and installation

When more units are used in combination with each other, more wiring is required.  
If communicating with the DL Series, this unit will send data to the PLC and only two wires are required to supply power to the main unit.

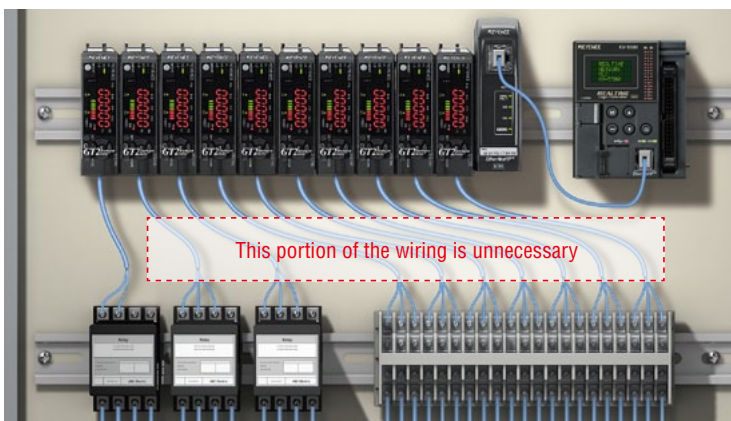

Reduce cable fabrication work

Reduce work wiring into terminal blocks

No terminal blocks required

## COST REDUCING MOUNTING METHODS

### ■ Greatly reduces design and fabrication time

The sensor can be mounted almost anywhere thanks to  $\varnothing 8$  mm slim body that can be mounted anywhere along its body. If you use one of the dedicated brackets, you do not need to fabricate a slotted jig. The flange type can also be directly mounted by simply drilling a  $\varnothing 10$  mm hole.

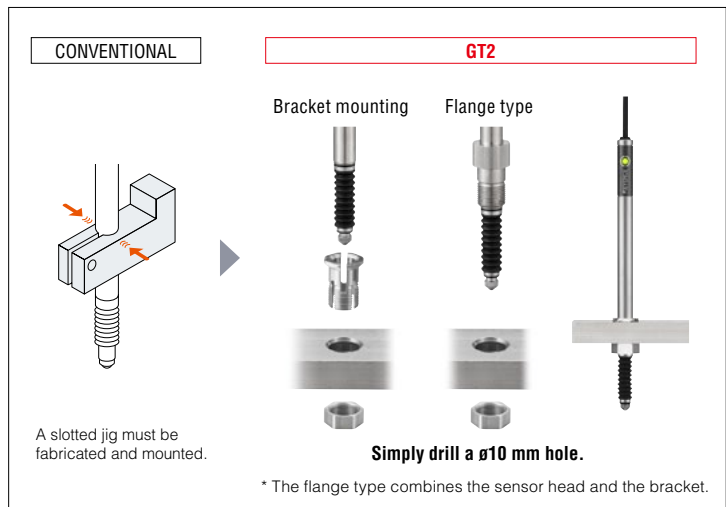
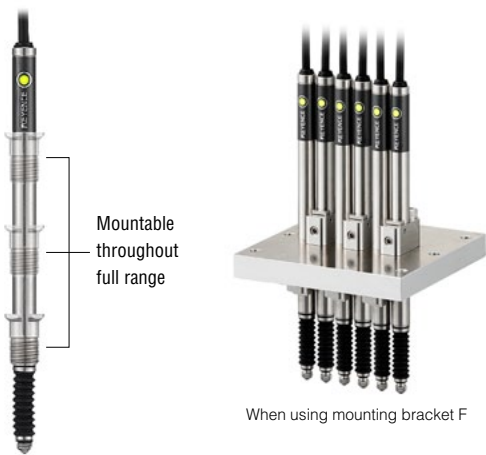

### ■ Air push type requires no drive mechanism

Measurements can be performed with the sensor head secured in place, so no mechanism is required to move the sensor head itself. This allows for space-saving installation which can greatly reduce costs at initial setup. Plus any worries about variations in accuracy due to the jig are eliminated.

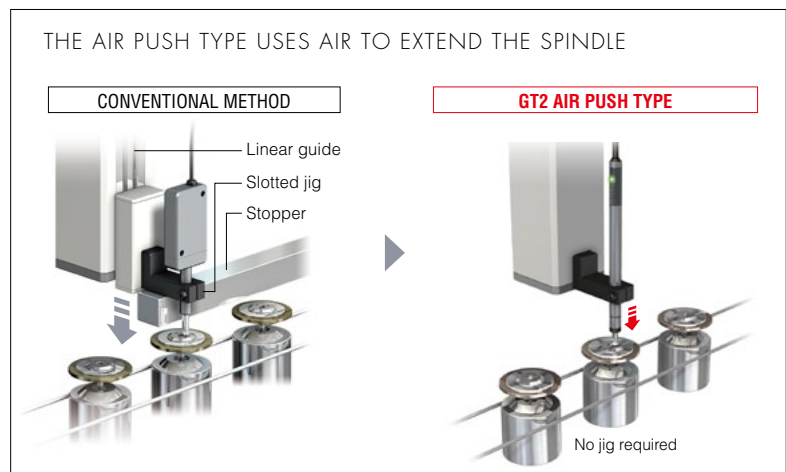
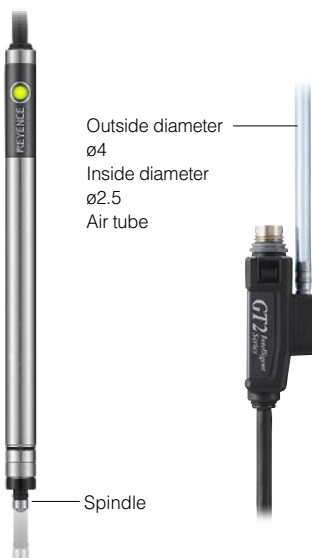

# REDUCE COSTS WITH MULTI-FUNCTION AMPLIFIER UNITS

## Simple calculations

A variety of detection modes are standard.

Calculations between additional amplifier units can be easily configured simply by selecting the desired mode.

Thickness



[SHAFT DIAMETER MEASUREMENT]

Positioning the target between two sensor heads will display the outer diameter.

Main unit		Expansion unit		Calculation result
<b>1000025</b>	+	<b>-00025</b>	=	<b>1000000</b>

Degree of flatness



[FLATNESS CHECK]

By subtracting the minimum value from the maximum value the flatness will be displayed.

Main unit		Expansion unit		Expansion unit		Expansion unit		Calculation result
<b>06510</b>		<b>06489</b>		<b>06423</b>		<b>06477</b>		<b>00087</b>
<b>06510</b>	-	<b>06423</b>	=	<b>00087</b>				
<small>Maximum value</small>		<small>Minimum value</small>						

VERSATILE DETECTION MODES SUPPORT ALL APPLICATIONS

**SINGLE HEAD**

Standard

Peak hold

Bottom hold

Peak to peak

**MULTIPLE HEADS/when additional amplifier units are installed (application modes)**

Maximum

Minimum

Degree of flatness

Average

Reference difference

Twist

Warpage





Thickness

## Total cost reductions

PLC programming or an analogue input card, which was required with LVDTs, is no longer necessary.

This leads to cost reductions.

CONVENTIONAL METHOD

+

+

+



**= Done**

GT2 SOLUTION

**EASY WAY**



+



= Done

**EASY WAY**



+











= Done

## SENSOR HEAD LINEUP



Select the sensor head by measuring range, appearance, resolution, accuracy, mounting method, and measuring force

### Pencil type

Measuring range	Accuracy	Standard		Flange	Air push
		Standard	Low stress	Standard	Standard
12 mm	<b>High-accuracy</b> Resolution 0.1 μm Accuracy 1 μm	<b>GT2-P12K</b> 	<b>GT2-P12KL</b> 	<b>GT2-P12KF</b> 	<b>GT2-PA12K</b> 
	<b>General-purpose</b> Resolution 0.5 μm Accuracy 2 μm	<b>GT2-P12</b> 	<b>GT2-P12L</b> 	<b>GT2-P12F</b> 	<b>GT2-PA12</b> 

### Sensor head cable

















Select by the distance between the sensor head and the amplifier unit, the environment, and the mounting method

Oil-resistant cable (straight) <sup>*1</sup>		Standard cable (straight)		Standard cable (L-shaped) <sup>*2</sup>	
					
<b>GT2-CHP2M</b>	2 m	<b>GT2-CH2M</b>	2 m	<b>GT2-CHL2M</b>	2 m
<b>GT2-CHP5M</b>	5 m	<b>GT2-CH5M</b>	5 m	<b>GT2-CHL5M</b>	5 m
<b>GT2-CHP10M</b>	10 m	<b>GT2-CH10M</b>	10 m	<b>GT2-CHL10M</b>	10 m
		<b>GT2-CH20M</b>	20 m	<b>GT2-CHL20M</b>	20 m

\*1 To satisfy NEMA Type 13/IP67G with GT2-P12(K)(F), the oil-resistant cable must be used.









\*2 Can only be used with the 12 mm type.

### Box type

Measuring range	Accuracy	Standard		Flange		Air push	
		Standard	Low stress	Standard	Low stress	Standard	Low stress
12 mm	<b>High-accuracy</b> Resolution 0.1 $\mu\text{m}$ Accuracy 1 $\mu\text{m}$	<b>GT2-H12K</b> 	<b>GT2-H12KL</b> 	<b>GT2-H12KF</b> 	<b>GT2-H12KLF</b> 	<b>GT2-A12K</b> 	<b>GT2-A12KL</b> 
	<b>General-purpose</b> Resolution 0.5 $\mu\text{m}$ Accuracy 2 $\mu\text{m}$	<b>GT2-H12</b> 	<b>GT2-H12L</b> 	<b>GT2-H12F</b> 	<b>GT2-H12LF</b> 	<b>GT2-A12</b> 	<b>GT2-A12L</b> 
32 mm	<b>General-purpose</b> Resolution 0.5 $\mu\text{m}$ Accuracy 3 $\mu\text{m}$	<b>GT2-H32</b> 	<b>GT2-H32L</b> 	-	-	<b>GT2-A32</b> 	-
50 mm	<b>General-purpose</b> Resolution 0.5 $\mu\text{m}$ Accuracy 3.5 $\mu\text{m}$	<b>GT2-H50</b> 	-	-	-	<b>GT2-A50</b> 	-

# AMPLIFIER UNIT LINEUP

Select according to the output method, mounting method, and number of connected units

Amplifier unit type	Appearance/model																								
Judgement output (5 outputs)	<p><b>DIN-rail mount type</b></p>  <p><b>Panel mount type</b></p>  <p>Connector type</p> 	<p><b>5-output function</b> Judges the 5 statuses HH/High/Go/Low/LL</p> <p><b>Bank function</b> Registers limit setting values and preset values in up to 4 different groups</p> <p><b>Calculation functions using expansion units</b> Enables calculations such as maximum value, minimum value, and degree of flatness</p> <table border="1" data-bbox="922 542 1417 721"> <tr> <td></td> <td></td> <td>Loose wire</td> <td>Connector</td> <td>Panel</td> </tr> <tr> <td rowspan="2">Main unit</td> <td>NPN</td> <td><b>GT2-71N</b></td> <td><b>GT2-71CN</b></td> <td><b>GT2-75N</b></td> </tr> <tr> <td>PNP</td> <td><b>GT2-71P</b></td> <td><b>GT2-71CP</b></td> <td><b>GT2-75P</b></td> </tr> <tr> <td rowspan="2">Expansion unit</td> <td>NPN</td> <td><b>GT2-72N</b></td> <td><b>GT2-72CN</b></td> <td><b>GT2-76N</b></td> </tr> <tr> <td>PNP</td> <td><b>GT2-72P</b></td> <td><b>GT2-72CP</b></td> <td><b>GT2-76P</b></td> </tr> </table>			Loose wire	Connector	Panel	Main unit	NPN	<b>GT2-71N</b>	<b>GT2-71CN</b>	<b>GT2-75N</b>	PNP	<b>GT2-71P</b>	<b>GT2-71CP</b>	<b>GT2-75P</b>	Expansion unit	NPN	<b>GT2-72N</b>	<b>GT2-72CN</b>	<b>GT2-76N</b>	PNP	<b>GT2-72P</b>	<b>GT2-72CP</b>	<b>GT2-76P</b>
		Loose wire	Connector	Panel																					
Main unit	NPN	<b>GT2-71N</b>	<b>GT2-71CN</b>	<b>GT2-75N</b>																					
	PNP	<b>GT2-71P</b>	<b>GT2-71CP</b>	<b>GT2-75P</b>																					
Expansion unit	NPN	<b>GT2-72N</b>	<b>GT2-72CN</b>	<b>GT2-76N</b>																					
	PNP	<b>GT2-72P</b>	<b>GT2-72CP</b>	<b>GT2-76P</b>																					
Analogue output (4 to 20 mA)	<p><b>DIN-rail mount type</b></p>  <p>Connector type</p> 	<p><b>3-output function</b> Judges the 3 statuses High/Go/Low</p> <p><b>Bank function</b> Registers limit setting values and preset values in up to 4 different groups</p> <p><b>Calculation functions using expansion units</b> Enables calculations such as maximum value, minimum value, and degree of flatness</p> <table border="1" data-bbox="922 967 1417 1057"> <tr> <td></td> <td></td> <td>Connector</td> </tr> <tr> <td rowspan="2">Main unit</td> <td>NPN</td> <td><b>GT2-71MCN</b></td> </tr> <tr> <td>PNP</td> <td><b>GT2-71MCP</b></td> </tr> </table>			Connector	Main unit	NPN	<b>GT2-71MCN</b>	PNP	<b>GT2-71MCP</b>															
		Connector																							
Main unit	NPN	<b>GT2-71MCN</b>																							
	PNP	<b>GT2-71MCP</b>																							
Pulse output	<p><b>DIN-rail mount type</b></p>  <p>Increment/decrement direction</p> <p>Pulse output resolution</p> <p>Minimum phase difference</p>	<p><b>Minimum phase difference selection</b> [0.5/2.5/5/25 μs]</p> <p>Capable of batch output of position information.</p> <table border="1" data-bbox="922 1258 1417 1326"> <tr> <td></td> <td></td> <td>Loose wire</td> </tr> <tr> <td>Main unit</td> <td>NPN</td> <td><b>GT2-71D</b></td> </tr> </table>			Loose wire	Main unit	NPN	<b>GT2-71D</b>																	
		Loose wire																							
Main unit	NPN	<b>GT2-71D</b>																							
Large display	<p><b>Panel mount type</b></p>  	<p>Easy operation with a large display and buttons. Up to 11 sensor heads can be connected using the expansion board. * With only the main body, up to 2 sensor heads can be connected</p> <table border="1" data-bbox="922 1550 1417 1697"> <tr> <td></td> <td></td> <td>Connector</td> </tr> <tr> <td rowspan="2">Main body</td> <td>NPN</td> <td><b>GT2-100N</b></td> </tr> <tr> <td>PNP</td> <td><b>GT2-100P</b></td> </tr> <tr> <td rowspan="2">Expansion board (3 sensor heads/1 board)</td> <td>NPN</td> <td><b>GT2-E3N</b></td> </tr> <tr> <td>PNP</td> <td><b>GT2-E3P</b></td> </tr> </table>			Connector	Main body	NPN	<b>GT2-100N</b>	PNP	<b>GT2-100P</b>	Expansion board (3 sensor heads/1 board)	NPN	<b>GT2-E3N</b>	PNP	<b>GT2-E3P</b>										
		Connector																							
Main body	NPN	<b>GT2-100N</b>																							
	PNP	<b>GT2-100P</b>																							
Expansion board (3 sensor heads/1 board)	NPN	<b>GT2-E3N</b>																							
	PNP	<b>GT2-E3P</b>																							
Multi-sensor amplifier unit	<p><b>DIN-rail mount type</b></p> 	<p>Up to 5 sensor heads can be connected to 1 amplifier unit Up to 15 sensor heads can be connected by adding 2 expansion units * A communication unit (DL Series) is required for output.</p> <table border="1" data-bbox="922 1908 1417 1998"> <tr> <td></td> <td></td> <td>Multi-head connection</td> </tr> <tr> <td>Main unit</td> <td></td> <td><b>GT2-500</b></td> </tr> <tr> <td>Expansion unit</td> <td></td> <td><b>GT2-550</b></td> </tr> </table>			Multi-head connection	Main unit		<b>GT2-500</b>	Expansion unit		<b>GT2-550</b>														
		Multi-head connection																							
Main unit		<b>GT2-500</b>																							
Expansion unit		<b>GT2-550</b>																							

Communication method	Model	Appearance	Judgement result readout	Measurement value readout	Control input	Modify tolerance value	Remarks
EtherNet/IP™	DL-EP1		◎	◎	◎	○	Uses cyclic communication. A communication program does not need to be created. Change settings using explicit message communication.
DeviceNet™	DL-DN1		◎	◎	◎	◎	Uses I/O communication. A communication program does not need to be created. Change settings using explicit message communication.
PROFINET	DL-PN1		◎	◎	◎	○	Uses data I/O communication. A communication program does not need to be created. Change settings using record data communication.
PROFIBUS	DL-PD1		◎	◎	◎	○	Uses cyclic transmissions. A communication program does not need to be created. Change settings using the DP-V1 service.
CC-Link	DL-CL1		◎	◎	◎	◎	Uses cyclic transmissions. A communication program does not need to be created. Change settings using handshake control.
RS-232C	DL-RS1A		○	○	○	○	Uses RS-232C communication. Communicate by creating a communication program.
BCD	DL-RB1A		×	○	×	×	Measurement values are synchronised and updated with the input terminal or automatically updated by timer. Values are synchronised and read by strobe output.

The ◎ symbol indicates wire savings and communication program creation is not required. ○=Can be accessed by creating a communication program. ×=Cannot be accessed.

SYSTEM CONFIGURATION

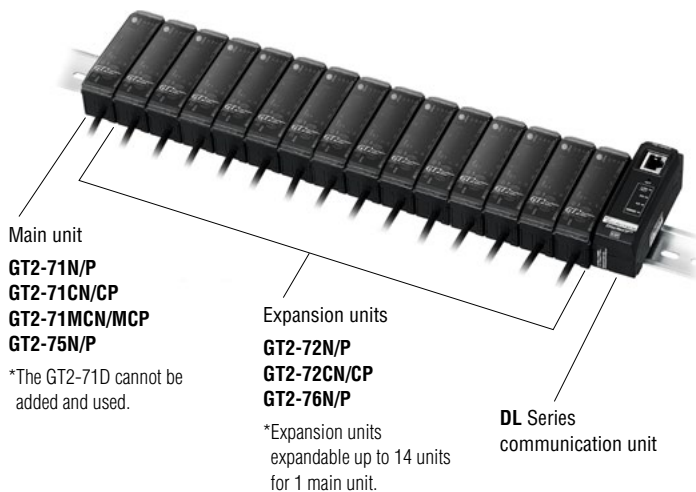

Adding expansion units to the main unit

**Expand with the side connector.**

To add a unit, please use the separately available end unit (OP-26751).

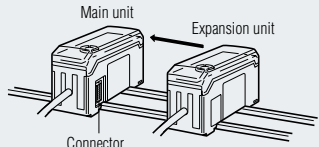

Main unit  
 Expansion unit  
 Connector

**Expand with the cable included with the expansion unit.**



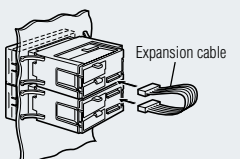

To add a unit, mount vertically with the main unit as the top unit.



Expansion cable

\* To mount horizontally, the separately available OP-35361 (expansion cable 300 mm) is required.

**Mounting brackets (GT2 12 mm type mounting brackets)**

 <p><b>GENERAL PURPOSE TYPE</b> Mounting bracket A <b>OP-76874</b></p>	 <p><b>SIDE MOUNTING TYPE</b> Mounting bracket B <b>OP-76875</b></p>
 <p><b>REINFORCED HOLDING FORCE TYPE</b> Mounting bracket C <b>OP-84396</b> Vibration resistant</p>	 <p><b>SIDE MOUNTING TYPE</b> Mounting bracket E <b>OP-87220</b> Reinforced holding force</p>
 <p><b>COUPLED MOUNTING TYPE</b> Mounting bracket F <b>OP-87863</b></p>	

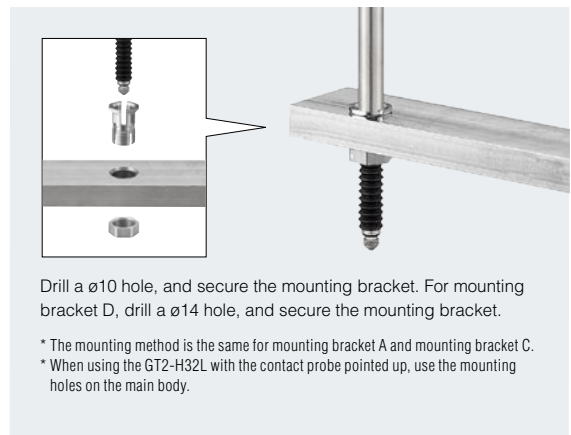

Drill a  $\phi 10$  hole, and secure the mounting bracket. For mounting bracket D, drill a  $\phi 14$  hole, and secure the mounting bracket.

- \* The mounting method is the same for mounting bracket A and mounting bracket C.
- \* When using the GT2-H32L with the contact probe pointed up, use the mounting holes on the main body.



Horizontal mounting.

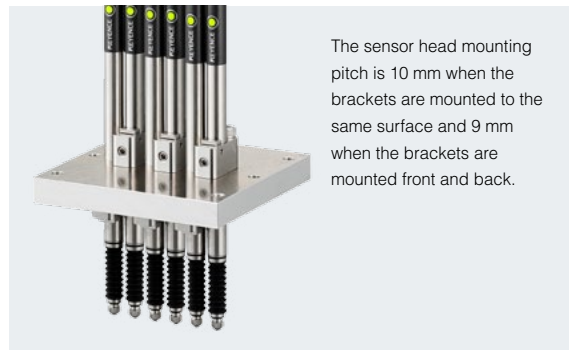

The sensor head mounting pitch is 10 mm when the brackets are mounted to the same surface and 9 mm when the brackets are mounted front and back.

**Mounting bracket (GT2 32 mm/50 mm type mounting brackets)**

 <p><b>REINFORCED HOLDING FORCE TYPE</b> Mounting bracket D <b>OP-84327</b> Vibration resistant</p>
--

**Contacts**

 <p><b>STANDARD<sup>*1</sup></b> <b>OP-77678</b> For standard measurements</p>	 <p><b>SUPER-TOUGH<sup>*2</sup></b> <b>OP-77682</b> Uses a super-tough alloy, for high-accuracy measurements</p>	 <p><b>STANDARD (small)<sup>*3</sup></b> <b>OP-87984</b> For standard measurements</p>	 <p><b>SUPER-TOUGH (small)<sup>*4</sup></b> <b>OP-87985</b> Uses a super-tough alloy, for high-accuracy measurements</p>	 <p><b>FLAT PLATE</b> <b>OP-77679</b> For objects with a curved or pointed surface</p>	 <p><b>ROLLER</b> <b>OP-77680</b> For moving objects</p>
 <p><b>FLUOROCARBON RESIN</b> <b>OP-80228</b> Made from material that is unlikely to damage the target's surface</p>	 <p><b>CERAMIC</b> <b>OP-81970</b> To electrically insulate the sensor from the target</p>	 <p><b>NEEDLE</b> <b>OP-77681</b> To measure in tight locations</p>	 <p><b>OFFSET</b> <b>OP-77683</b> For multiple measurements of a small object</p>	 <p><b>SPACER</b> <b>OP-77684</b> Extends the spindle 12.2 mm</p>	 <p><b>ROLLER (HIGH-ACCURACY)</b> <b>OP-93332</b> For use when the roller eccentricity is a concern</p>

\*1 Standard on the GT2-P(A)12(L/F), GT2-H(A)12(L/F/LF), GT2-H(A)32(L), GT2-H(A)50

\*2 Standard on the GT2-P(A)12K(L/F), GT2-H(A)12K(L/F/LF)





\*3 Standard on the GT2-PA12

\*4 Standard on the GT2-PA12K





## Dust boots/Dust seal

 <p><b>STANDARD DUST BOOT</b> (material: NBR) For 12 mm <b>OP-84332</b> For 32 mm <b>OP-84459</b> For 50 mm <b>OP-84460</b> Cannot be used with the GT2-PA12K/PA12.</p>	 <p><b>FLUOROCARBON RUBBER DUST BOOT</b> (material: FKM) For 12 mm <b>OP-87859</b> Cannot be used with the GT2-PA12K/PA12.</p>	 <p><b>REPLACEMENT DUST SEAL</b> (material: SUS303) <b>OP-87932</b> Dedicated for use with the GT2-PA12K/PA12.</p>
--	---	---

## Amplifier unit options (for DIN-rail mount/panel mount types)

 <p><b>DIN-RAIL TYPE AMPLIFIER UNIT BRACKET</b> <b>OP-76877</b></p>	 <p><b>END UNIT (2 count)</b> <b>OP-26751</b></p>	 <p><b>SOCKET CABLE</b> <b>GT2-CA2M/CA10M</b> Required with the connector type</p>	 <p><b>PANEL MOUNT</b> <b>OP-84394</b> Included with the panel type</p>	 <p><b>EXPANSION CABLE</b> 300 mm <b>OP-35361</b> To connect panel types horizontally, and to connect the panel type and the DL</p>
--	--	---	---	--

## Amplifier unit options (for the GT2-100N/100P)

 <p><b>EXPANSION BOARD</b> <b>GT2-E3N/E3P</b> Can expand 3 sensor heads per 1 board</p>	 <p><b>BRACKET</b> <b>OP-84331</b> To mount on a rack</p>	 <p><b>20-PIN MIL CONNECTOR</b> <b>OP-22185</b> For 1 to 2 sensor heads</p>	 <p><b>30-PIN MIL CONNECTOR</b> <b>OP-84456</b> For the expansion board</p>
 <p><b>CONTACTS</b> for AWG24 to 22, 200 count <b>OP-22186</b> For OP-22185/84456</p>	 <p><b>CONTACTS</b> for AWG28 to 26, 200 count <b>OP-30594</b> For OP-22185/84456</p>	 <p><b>SPECIAL CRIMPING TOOL</b> <b>OP-21734</b> For crimping OP-22186/30594</p>	 <p><b>EXPANSION CABLE</b> 300 mm <b>OP-35361</b> Use when connecting the DL</p>

## Others

 <p><b>SPEED CONTROLLER</b> <b>OP-87970</b> For adjusting the air for air push type</p>	 <p><b>LIFT LEVER</b> <b>OP-84397</b> Manually lifts the spindle</p>	 <p><b>SENSOR HEAD RELAY CABLE</b> <b>OP-87431/87432/87433</b> M8-M8 relay cable 3.5 m/7.5 m/9.0 m</p>	 <p><b>CONNECTORS</b> Replacements for connecting to the amplifier unit <b>OP-84338 (2 count)</b> For the sensor head cable</p>	 <p><b>COILING TUBE</b> <b>OP-87986</b> For air push type</p>
--	---	---	---	--

AUTOMOBILES



Flatness measurement of engine block

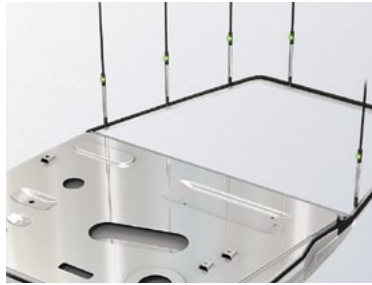

Door beam deformation check

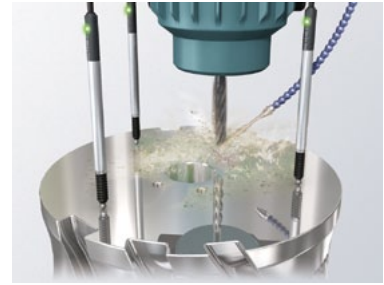

Disc assembly inspection



Camshaft runout measurement



Side mirror angle inspection



Oil pan flatness measurement

METALS



Bearing assembly inspection



Mill roll gap management

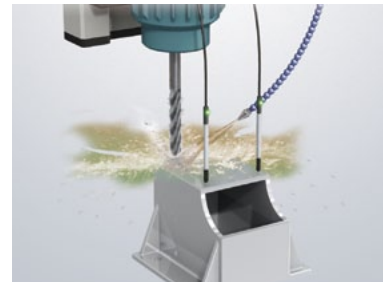

Dimensional measurement during machining

EQUIPMENT

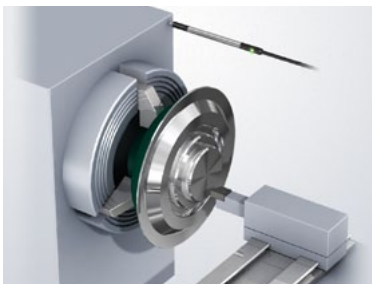

Machine tool stroke management

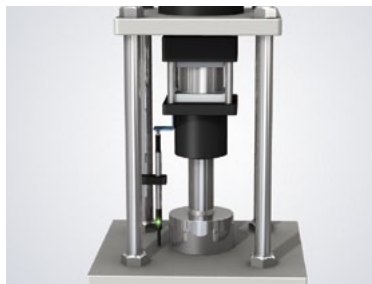

Assembly equipment press fitting inspection



Product chucking confirmation

## ELECTRONICS



Battery flatness check



Smartphone chassis flatness inspection

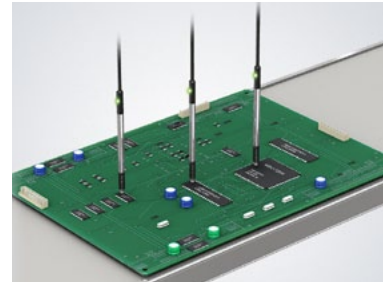

Board assembly check



Hard disk frame assembly inspection

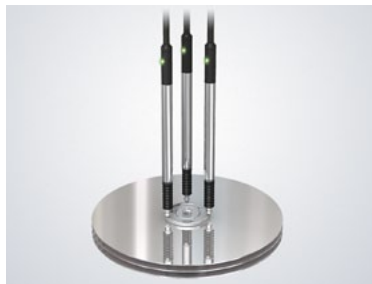

Hard disk clamp parallelism inspection

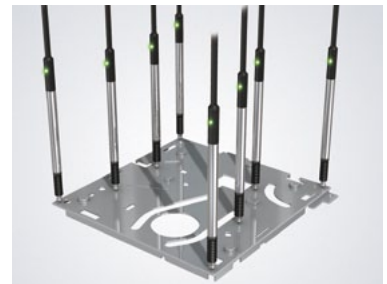

Chassis frame warpage inspection

## SEMICONDUCTORS/LIQUID CRYSTALS



Polisher height control

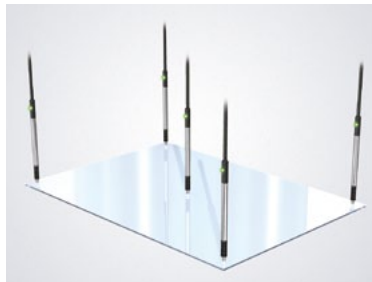

Liquid crystal panel flatness inspection

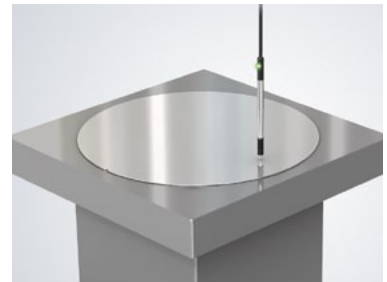

Wafer thickness measurement

## FOOD/PRINTING



Double label stickers detection

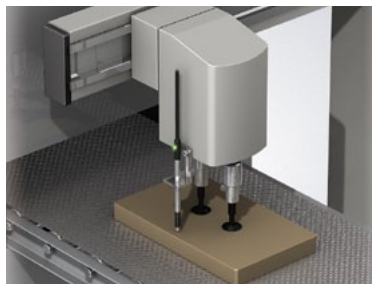









Workpiece suction check



Double feed detection

# SPECIFICATIONS

## Pencil type (The GT2-PA12K/PA12 is an air push type)

Model	GT2-P12K	GT2-P12KF	GT2-P12KL	GT2-P12	GT2-P12F	GT2-P12L	GT2-PA12K	GT2-PA12	
Appearance									
Detection system	Scale Shot System II, absolute (no tracking errors) type								
Measuring range	12 mm								
Resolution	0.1 µm			0.5 µm			0.1 µm	0.5 µm	
Indicated accuracy*1	1 µm (P-P)			2 µm (P-P)			1 µm (P-P)	2 µm (P-P)	
Measuring force *2	Downward mounting	1.0 N	0.2 N	1.0 N	0.2 N	1.2 N			
	Side mounting	0.95 N	0.15 N	0.95 N	0.15 N	1.15 N			
	Upward mounting	0.9 N	0.1 N	0.9 N	0.1 N	1.1 N			
Sampling cycle	4 ms								
Mechanical response*1	10 Hz	4 Hz	10 Hz	4 Hz					
Applied pressure range							0.24 MPa to 0.26 MPa		
Pressure resistance							0.5 MPa		
Fluid used							Clean dry air		
Operation indicator	2-colour LED (red, green)								
Environmental resistance	Enclosure rating	IP67G (JIS)*3 IP67 (IEC) NEMA Type 13*3		-	IP67G (JIS)*3 IP67 (IEC) NEMA Type 13*3		-	IP67 (IEC)	
	Ambient temperature	-10 to +55°C (No freezing)						0 to +55°C (No freezing)	
	Relative humidity	35 to 85% RH (No condensation)							
	Vibration	10 to 55 Hz Double amplitude 1.5 mm in the X, Y, Z axis directions respectively, 2 hours							
Impact resistance	1000 m/s <sup>2</sup> (IEC60068-2-27)								
Materials	Main body	Main body case: SUS 303, Status indicator: PET, Sensor head-relay connector cable: PUR, Relay connector: PBT, Spindle of GT2-PA12K/PA12: SUS430 (Fluorine coating)							
	Dustboot	NBR		-	NBR				
	Contact*4	SUS304, cemented tungsten carbide			SUS304, SUS440C			SUS304, cemented tungsten carbide	SUS304, SUS440C
Sensor head cable	Optional (connect to relay connector)								
Weight (not including cable)*5	Approx. 35 g	Approx. 45 g	Approx. 35 g	Approx. 45 g	Approx. 35 g				

\*1 Value when the ambient temperature is 20°C.

\*2 Representative value at the centre of the measuring range. Please note that the measuring force varies by the installation state of the dust boot.

This is a representative value when using the GT2-PA12K/PA12 with a pressure of 0.25 MPa. The measuring force varies depending on the air pressure used. For details, see table 1.  
No dust boots are used with the GT2-PA12K/PA12.

\*3 When an M8 oil-resistant cable (GT2-CHP2M/CHP5M/CHP10M) is used for the sensor head cable.

\*4 Contacts are available as options sold separately.

\*5 Including the relay connector.

Note: You may not be able to connect the sensor head to the amplifier unit depending on when the amplifier unit was purchased. For details, contact your local sales office.

Measuring force (N)

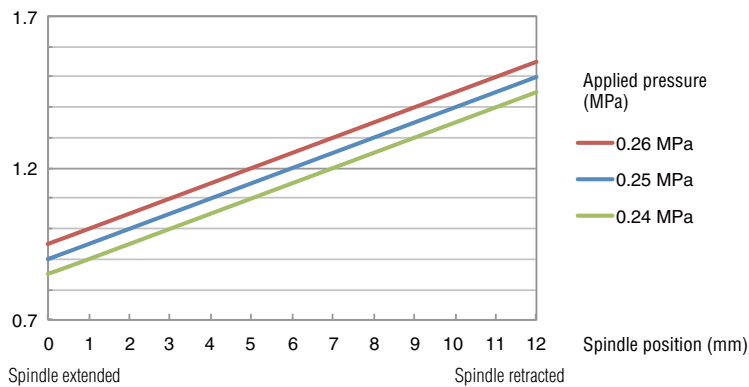









Table 1. Relationship between spindle position and measuring force according to air pressure.  
(When mounting sideways, the measuring force is -0.05 N.  
When mounting upwards, the measuring force is -0.1 N.)

## Box type



Model	GT2-H12K	GT2-H12KF	GT2-H12KL	GT2-H12KLF	GT2-H12	GT2-H12F	GT2-H12L	GT2-H12LF	
Appearance									
Detection system	Scale Shot System, absolute (no tracking errors) type								
Measuring range					12 mm				
Resolution	0.1 µm				0.5 µm				
Indicated accuracy*1	1 µm (P-P)				2 µm (P-P)				
Measuring force *2	Downward mounting	1.0 N		0.4 N		1.0 N		0.4 N	
	Side mounting	0.9 N		0.3 N		0.9 N		0.3 N	
	Upward mounting	0.8 N		0.2 N		0.8 N		0.2 N	
Sampling cycle	1 ms								
Mechanical response*1	10 Hz		4 Hz		10 Hz		4 Hz		
Operation indicator	2-colour LED (red, green)								
Environmental resistance	Enclosure rating	IP67 (IEC)		-		IP67 (IEC)		-	
	Ambient temperature	-10 to +55°C (No freezing)							
	Relative humidity	35 to 85% RH (No condensation)							
	Vibration	10 to 55 Hz Double amplitude 1.5 mm in the X, Y, Z axis directions respectively, 2 hours							
Materials	Impact resistance	1000 m/s² (IEC60068-2-27)							
	Main body	Main body case: die-cast zinc, Indicator: polyarylate (PAR)							
	Dustboot	NBR		-		NBR		-	
Contact*3	SUS304, cemented tungsten carbide				SUS304, SUS440C				
Sensor head cable	Optional (connect to the M8 connector)								
Weight (not including cable)	Approx. 95 g	Approx. 100 g	Approx. 95 g	Approx. 100 g	Approx. 95 g	Approx. 100 g	Approx. 95 g	Approx. 100 g	

\*1 Value when the ambient temperature is 20°C.

\*2 Representative value at the centre of the measuring range. Please note that the measuring force varies by the installation state of the dust boot.

\*3 Contacts are available as options sold separately.

## Box type (long range type)

Model	GT2-H32	GT2-H32L	GT2-H50	
Appearance				
Detection system	Scale Shot System, absolute (no tracking errors) type			
Measuring range	32 mm		50 mm	
Resolution			0.5 µm	
Indicated accuracy*1	3 µm (P-P)		3.5 µm (P-P)	
Measuring force *2	Downward mounting	2.1 N	1.2 N	
	Side mounting	1.8 N	0.9 N	
	Upward mounting	1.5 N	0.6 N	
Sampling cycle	1 ms			
Mechanical response*1	6 Hz	5 Hz	7 Hz	
Operation indicator	2-colour LED (red, green)			
Environmental resistance	Enclosure rating	IP67 (IEC)	IP67 (IEC)	
	Ambient temperature	-10 to 55°C (No freezing)		
	Relative humidity	35 to 85% RH (No condensation)		
	Vibration	10 to 55 Hz Double amplitude 1.5 mm in the X, Y, Z axis directions respectively, 2 hours		
Materials	Main body	Main body case: die-cast zinc, Indicator: polyarylate (PAR)		
	Dustboot	NBR	-	NBR
	Contact*3	SUS304, SUS440C		
Sensor head cable	Optional (connect to the M8 connector)			
Weight (not including cable)	Approx. 270 g		Approx. 320 g	





\*1 Value when the ambient temperature is 20°C.

\*2 Representative value at the centre of the measuring range. Please note that the measuring force varies by the installation state of the dust boot.

\*3 Contacts are available as options sold separately.

# SPECIFICATIONS

## Box type (air push type)

Model	GT2-A12K	GT2-A12KL	GT2-A12	GT2-A12L	
Appearance					
Detection system	Scale Shot System, absolute (no tracking errors) type				
Measuring range	12 mm				
Resolution	0.1 µm		0.5 µm		
Indicated accuracy*1	1 µm (P-P)		2 µm (P-P)		
Measuring force*2	Downward mounting	1.2 N	0.4 N	1.2 N	0.4 N
	Side mounting	1.1 N	0.3 N	1.1 N	0.3 N
	Upward mounting	1.0 N	0.2 N	1.0 N	0.2 N
Sampling cycle	1 ms				
Applied pressure range	0.25 MPa to 0.50 MPa				
Pressure resistance	1 MPa				
Fluid used	Dry air				
Operation indicator	2-colour LED (red, green)				
Environmental resistance	Enclosure rating	IP67 (IEC)*3	-	IP67 (IEC)*3	-
	Ambient temperature	0 to +55°C (No freezing)			
	Relative humidity	35 to 85% RH (No condensation)			
	Vibration	10 to 55 Hz Double amplitude 1.5 mm in the X, Y, Z axis directions respectively, 2 hours			
	Impact resistance	1000 m/s <sup>2</sup> (IEC60068-2-27)			
Materials	Main body	Main body case: die-cast zinc, Cylinder section: aluminium alloy, Air joint resin: polyacetal, Air joint metal: nickel-plated brass, Indicator: polyarylate (PAR)			
	Dustboot	NBR	-	NBR	-
	Contact*4	SUS304, cemented tungsten carbide		SUS304, SUS440C	
Sensor head cable	Optional (connect to the M8 connector)				
Weight (not including cable)	Approx. 145 g				



\*1 Value when the ambient temperature is 20°C.

\*2 Representative value at the centre of the measuring range. Please note that the measuring force varies by the installation state of the dust boot.

\*3 Connect an exhaust joint to the air tube and ensure that foreign matter does not enter the tube from joint.

\*4 Contacts are available as options sold separately.

## Box type (air push type/long range type)

Model	GT2-A32	GT2-A50	
Appearance			
Detection system	Scale Shot System, absolute (no tracking errors) type		
Measuring range	32 mm	50 mm	
Resolution	0.5 µm		
Indicated accuracy*1	3 µm (P-P)	3.5 µm (P-P)	
Measuring force*2	Downward mounting	2.1 N	3.2 N
	Side mounting	1.8 N	2.8 N
	Upward mounting	1.5 N	2.4 N
Sampling cycle	1 ms		
Applied pressure range	0.25 MPa to 0.50 MPa		
Pressure resistance	1 MPa		
Fluid used	Dry air		
Operation indicator	2-colour LED (red, green)		
Environmental resistance	Enclosure rating	IP67 (IEC)*3	
	Ambient temperature	0 to +55°C (No freezing)	
	Relative humidity	35 to 85% RH (No condensation)	
	Vibration*4	10 to 55 Hz Double amplitude 1.5 mm in the X, Y, Z axis directions respectively, 2 hours	
Materials	Main body	Main body case: die-cast zinc, Cylinder section: aluminium alloy, Air joint resin: polyacetal, Air joint metal: nickel-plated brass, Indicator: polyarylate (PAR)	
	Dustboot	NBR	
	Contact*5	SUS304, SUS440C	
Sensor head cable	Optional (connect to the M8 connector)		
Weight (not including cable)	Approx. 340 g	Approx. 405 g	

\*1 Value when the ambient temperature is 20°C.



\*2 Representative value at the centre of the measuring range. Please note that the measuring force varies by the installation state of the dust boot.

\*3 Connect an exhaust joint to the air tube and ensure that foreign matter does not enter the tube from joint.

\*4 When using mounting bracket D (OP-84327), the double amplitude is 0.75 mm.

\*5 Contacts are available as options sold separately.

### Judgement output/analogue output type

Model	NPN output	Main unit	GT2-71(C)N	GT2-75N	GT2-71MCN
	PNP output	Expansion unit *1		GT2-76N	-
PNP output		Main unit	GT2-71(C)P	GT2-75P	GT2-71MCP
	Expansion unit *1		GT2-72(C)P	GT2-76P	-
Appearance					
Mounting type*2			DIN-rail mount	Panel mount	DIN-rail mount
Number of expansion units *1	Up to 14 expansion units for 1 main unit				
Power supply voltage *1	10 to 30 VDC, including 10% ripple (P-P), Class 2			20 to 30 VDC, including 10% ripple (P-P), Class 2	
Display range	-199.999.9 to 199.999.9				
Display resolution	0.1 μm				
Power consumption	Normal	2200 mW or less (73.3 mA or less at 30 V)		2700 mW or less (90.0 mA or less at 30 V)	
	Power saving (Eco half)	1800 mW or less (60.0 mA or less at 30 V)		2300 mW or less (76.7 mA or less at 30 V)	
	Power saving (Eco all)	1700 mW or less (56.7 mA or less at 30 V)		2200 mW or less (73.3 mA or less at 30 V)	
Response time	hsp (3)/5/10/100/500/1000 ms (When using GT2-Pxxx, hsp (12)/20/40/400/2000/4000 ms)				
Control output (HH/HI/GO/LO/LL)*3	NPN output	NPN open collector, 40 V 50 mA or less, residual voltage 1 V or less*1			
	PNP output	PNP open collector, 30 V 50 mA or less, residual voltage 1 V or less *1			
Control input	Timing/preset/reset/bank input	No-voltage input			
Analogue output	Output range	-			4 to 20 mA with a max. load resistance of 350 Ω
	Response time	-			Set response time + 1 ms
Environmental resistance	Ambient temperature	-10 to +50°C (No freezing)*1			
	Relative humidity	35 to 85% RH (No condensation)			
	Vibration	10 to 55 Hz Double amplitude 1.5 mm in the X, Y, Z axis directions respectively, 2 hours			
Materials	Main body case/front cover: polycarbonate (PC), Key top: polyacetal (POM), Front sheet: polyethylene terephthalate (PET), Cable: polyvinyl chloride (PVC)				
Weight	GT2-71N(P)/72N(P)	Approx. 140 g (including power supply cable)			
	GT2-75N(P)/76N(P)	Approx. 140 g (including panel mount, front protective cover, power supply cable)			
	GT2-71MCN(P)/71CN(P)/72CN(P)	Approx. 70 g (not including the GT2-CA2M/CA5M/CA10M)			

\*1 When adding expansion units, there are the following restrictions according to the number of connected units.

- When 2 to 8 units are connected including the main unit
  - Power supply voltage: 20 to 30 VDC
  - Control output current: 20 mA or less
  - (GT2-71MCN(P) only) Ambient temperature: -10 to 45°C
- When 9 to 15 units are connected including the main unit
  - Power supply voltage: 20 to 30 VDC
  - Control output current: 10 mA or less (including the DL-RB1A output current)
  - Residual voltage: 1.5 V or lower
  - (GT2-71MCN(P) only) Ambient temperature: -10 to 45°C

\*2 When using the DIN-rail mount type, always mount it to a DIN-rail (mounted to a metal plate), and when adding expansion units, always use the end unit (OP-26751).



\*3 The GT2-71MCN(P) does not have HH/LL.

### Pulse output type

Model	GT2-71D				
Appearance					
Mounting type	DIN-rail mount				
Number of expansion units	Only 1 unit				
Power supply voltage	10 to 30 VDC, including 10% ripple (P-P), Class 2				
Power consumption	1600 mW or less (53.3 mA or less at 30 V)				
Indicators	Power supply (green)/alarm (red) indicator, pulse output indicator (green), input indicator				
Pulse resolution	Select from 0.1/0.5/1/10 μm (when shipped: 0.5 μm)				
Minimum phase difference	Select from 0.5/2.5/5/25 μs (when shipped: 2.5 μs)				
Control input	Origin return	No-voltage input (contact, non-contact)			
Output signal	90° phase difference, differential square wave (EIA-422 compliant) 4x multiplier				
Output signal level	+5 V				
Environmental resistance	Ambient temperature	-10 to +50°C (No freezing)			
	Relative humidity	35 to 85% RH (No condensation)			
	Vibration	10 to 55 Hz Double amplitude 1.5 mm in the X, Y, Z axis directions respectively, 2 hours			
Materials	Main body case/front cover: polycarbonate (PC), Cable: polyvinyl chloride (PVC)				
Weight	Approx. 110 g (including power supply cable)				

# SPECIFICATIONS

## Large display type

Model	NPN output	GT2-100N	GT2-E3N
	PNP output	GT2-100P	GT2-E3P
Appearance			
Mounting type	Panel mount		-
Number of connectable heads	2 heads with GT2-100N(P) alone + 3 heads per 1 head board expansion When expanded with a maximum of 3 head boards, 11 heads		-
Power supply voltage	10 to 30 VDC, including 10% ripple (P-P), Class 2		Supplied from the GT2-100N/100P
Display range	-199.999.9 to 199.999.9		-
Display resolution	0.1 μm		-
Power consumption	Normal	4500 mW or less (150.0 mA or less at 30 V)	4200 mW or less (140.0 mA or less at 30 V)
	Power saving (Eco half) *1	3700 mW or less (123.3 mA or less at 30 V)	4200 mW or less (140.0 mA or less at 30 V)
	Power saving (Eco all) *1	3600 mW or less (120.0 mA or less at 30 V)	4000 mW or less (133.3 mA or less at 30 V)
Response time	hsp (3)/5/10/100/500/1000 ms (When using GT2-Pxxx, hsp (12)/20/40/400/2000/4000 ms)		
Control output (HH/HI/GO/LO/LL)	NPN output	NPN open collector, 40 V 50 mA or less*3, residual voltage 1 V or less	
	PNP output	PNP open collector, 30 V 50 mA or less*3, residual voltage 1 V or less	
Control input	Timing/preset/ reset/bank input	No-voltage input	
Input/output connector *2	Power supply: Terminal block connection Input/output: 20-pin connector (MIL standard)		30-pin connector (MIL standard)
Environmental resistance	Ambient temperature	-10 to +50°C (No freezing)	
	Relative humidity	35 to 85% RH (No condensation)	
	Vibration	10 to 55 Hz Double amplitude 0.15 mm in the X, Y, Z axis directions respectively, 2 hours	
Materials	Main body case/front cover: polycarbonate (PC), Key top: polyacetal (POM), Front sheet: polyethylene terephthalate (PET)		-
Weight	Approx. 380 g		Approx. 80 g

\*1 When the maximum number of sensor heads is connected, and all devices are set to power saving settings

\*2 The connector and cable are sold separately.

\*3 When 2 or more sensor heads are connected, 20 mA or less.

## Multi-head type

Model	Main unit	GT2-500
	Expansion unit	GT2-550
Appearance		
Mounting type *1	DIN-rail mount	
Number of expansion units *2	Maximum of 3 units including the main unit (Maximum of 15 sensor heads)	
Power supply voltage	20 to 30 VDC, including 10% ripple (P-P) (GT2-550 power supplied from the main unit), Class 2	
Consumption current	4800 mW 160.0 mA or less at 30 V	
Response time	hsp (3)/5/10/100/500/1000 ms (When using GT2-Pxxx, hsp (12)/20/40/400/2000/4000 ms)	
Environmental resistance	Ambient temperature	-10 to +50°C
	Relative humidity	35 to 85% RH (No condensation)
	Vibration	10 to 55 Hz Double amplitude 1.5 mm in the X, Y, Z axis directions respectively, 2 hours
Materials	Main body case: polycarbonate, Cable: PVC	
Weight	GT2-500: Approx. 140 g, GT2-550: Approx. 95 g	

\*1 When connecting the DL Series and expansion units, always connect them when the amplifier unit is connected to the DIN-rail and use the end unit (OP-26751 included with the DL Series).

\*2 When using the DL-RB1A (for communication), ensure that the output current is 10 mA or less.

Sensor head (standard)  
GT2-P12K/  
GT2-P12

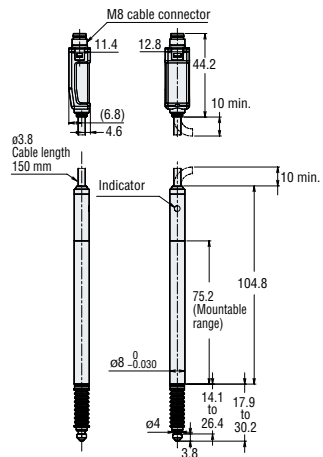

Sensor head (low stress)  
GT2-P12KL/  
GT2-P12L

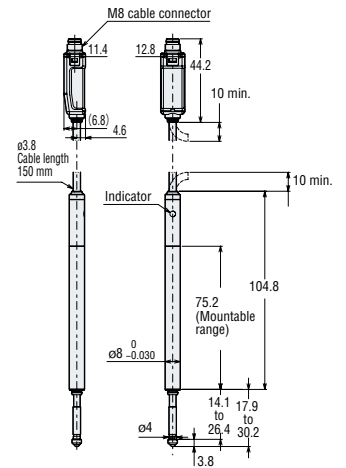
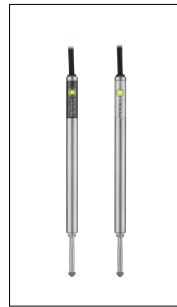

Sensor head (flange)  
GT2-P12KF/  
GT2-P12F

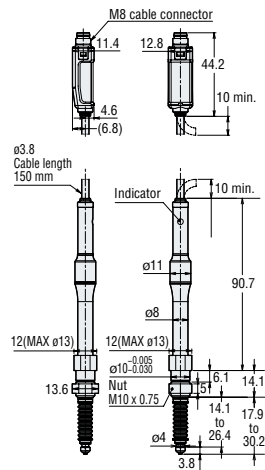

Sensor head (Air push)  
GT2-PA12K/  
GT2-PA12

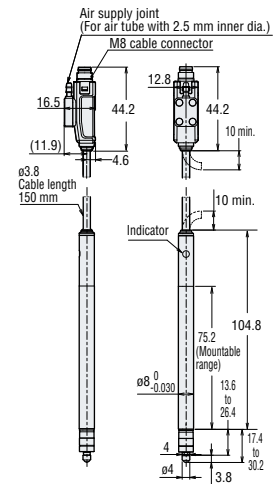

Sensor head - Sensor head cable  
When attached

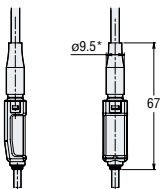

\* When using GT2-CHP2M/CHP5M/CHP10M,  $\phi 10$



Sensor head  
(Standard)  
**GT2-H50**

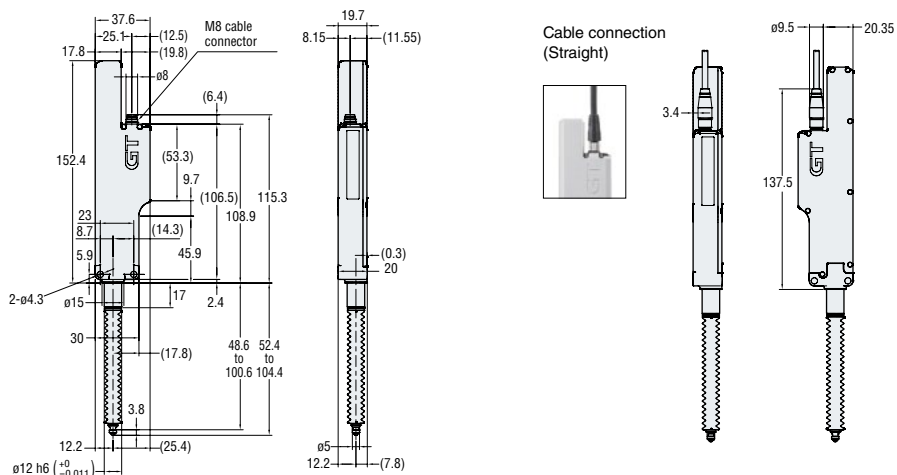

Sensor head  
(Air push)  
**GT2-A12K/GT2-A12**



There are no dust boots on the low stress type GT2-A12L/A12KL

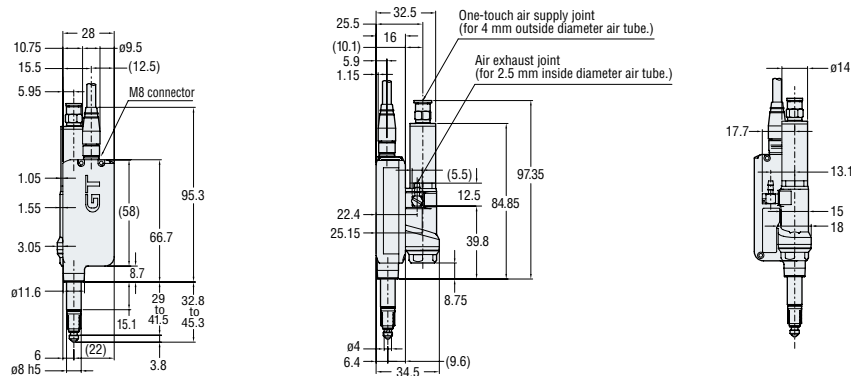

Sensor head  
(Air push)  
**GT2-A32**

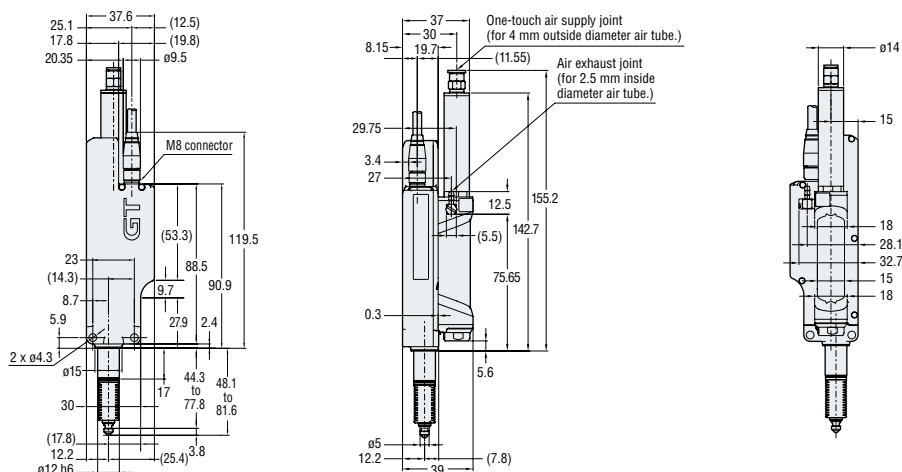

Sensor head  
(Air push)  
**GT2-A50**

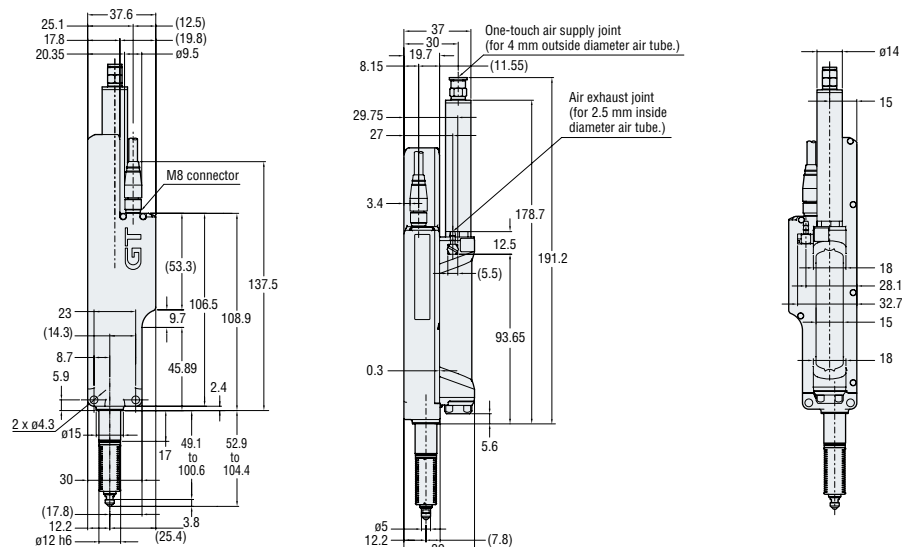

# DIMENSIONS

## Amplifier unit DIN-rail mount type



### GT2-71N/71P/71MCN/71MCP/71CN/71CP

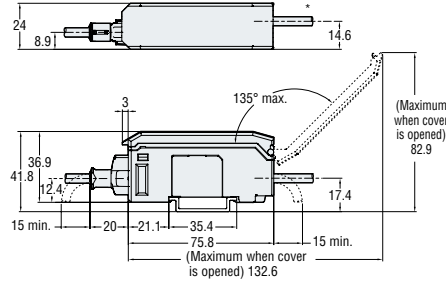

### GT2-72N/72P/72CN/72CP

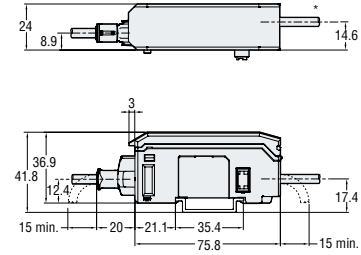

\* Cable specifications  
 GT2-71N/71P: ø4.7, 12-core x Brown/Blue: 0.20 mm<sup>2</sup>, Black/White/Grey/Orange/Green/Pink/Purple/Yellow/Red/Pink purple: 0.15 mm<sup>2</sup>, Cable length: 2 m  
 GT2-72N/72P: ø4.7, 10-core x Black/White/Grey/Orange/Green/Pink/Purple/Yellow/Red/Pink purple: 0.15 mm<sup>2</sup>, Cable length: 2 m

### GT2-71MCN/71MCP/71CN/71CP/72CN/72CP

Connector  
 (connector type/analogue output type amplifier unit)

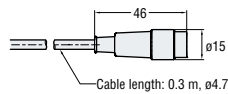

### GT2-CA2M/CA10M

Connection cable

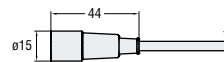

\* Cable specifications  
 Outer diameter: ø4.7 mm, Cable length: 2 m (GT2-CA2M), 10 m (GT2-CA10M),  
 12-core x Brown/Blue: 0.20 mm<sup>2</sup>, Black/White/Grey/Orange/Green/Pink/Purple/  
 Yellow/Red/Pink purple: 0.15 mm<sup>2</sup>

## Amplifier unit Pulse output



### GT2-71D

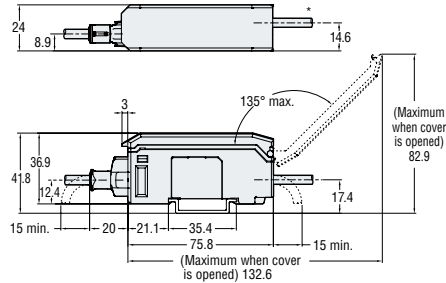

\* Cable specifications  
 Outer diameter: ø4.7 mm, Cable length: 2 m,  
 9-core x Brown/Blue/Purple/Pink/Orange/Green/Grey/White/Black: 0.15 mm<sup>2</sup>

## Mounting bracket for DIN-rail mount type amplifier (Optional) OP-76877

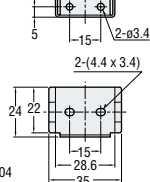

Material: SUS304

## End unit (Optional) (2 pcs.) OP-26751

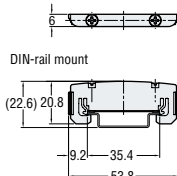

Material: Polycarbonate, Stainless steel

## When several units are connected

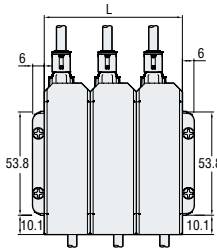

Number of units	L
1	24
2	48
3	72
4	96
5	120
6	144
7	168
8	192
9	216
10	240
11	264
12	288
13	312
14	336
15	360

## Amplifier unit Panel mount type



### GT2-75N/75P/76N/76P

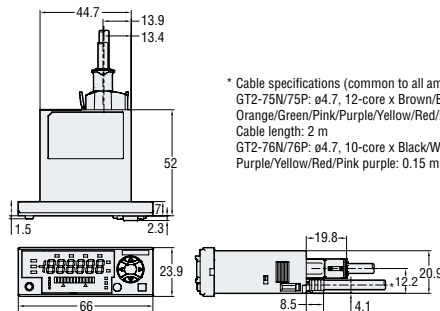

\* Cable specifications (common to all amplifier units)  
 GT2-75N/75P: ø4.7, 12-core x Brown/Blue: 0.20 mm<sup>2</sup>, Black/White/Grey/  
 Orange/Green/Pink/Purple/Yellow/Red/Pink purple: 0.15 mm<sup>2</sup>,  
 Cable length: 2 m  
 GT2-76N/76P: ø4.7, 10-core x Black/White/Grey/Orange/Green/Pink/  
 Purple/Yellow/Red/Pink purple: 0.15 mm<sup>2</sup>, Cable length: 2 m

## Panel mounting bracket (Accessory) OP-84394



## Panel cutout

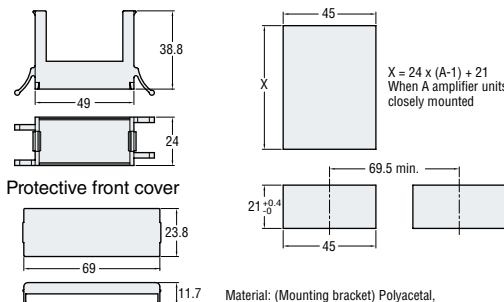

Material: (Mounting bracket) Polyacetal,  
 (Protective front cover) Polycarbonate

## Panel mounting bracket

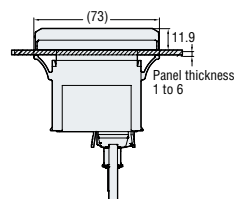

**Amplifier unit  
Large display  
GT2-100N/100P**



**When the supplied mounting bracket is attached**

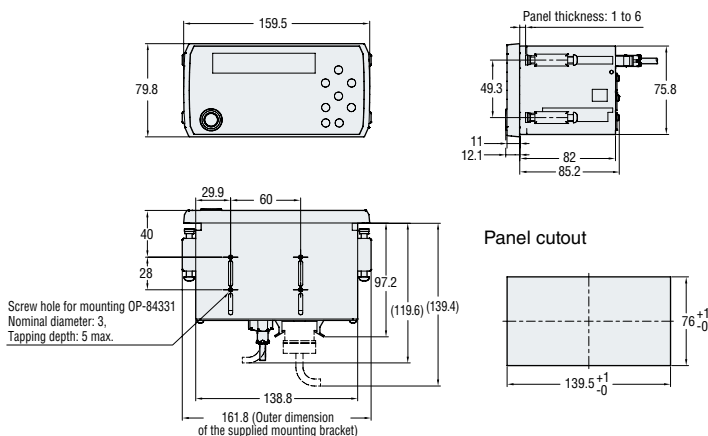

**GT2-E3N/E3P Expansion board**

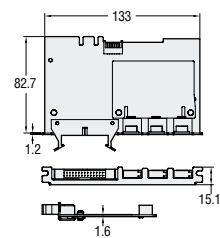

**When the optional mounting bracket (OP-84331) is used**

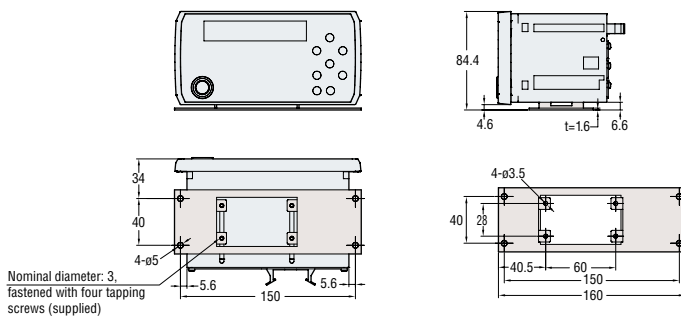

**Amplifier unit  
Multi-head type main unit  
GT2-500**



**Amplifier unit  
Multi-head type expansion unit  
GT2-550**

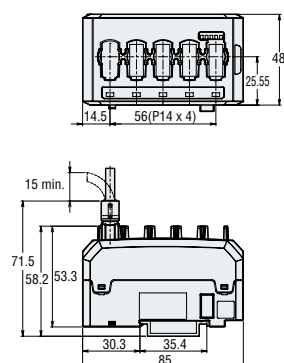
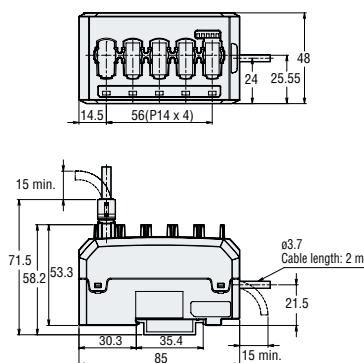

**When amplifier units are added**

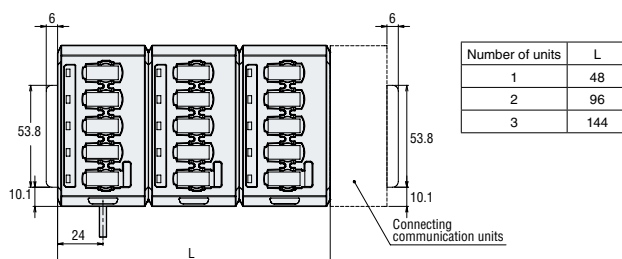

Sensor head mounting bracket A (Optional)  
**OP-76874**

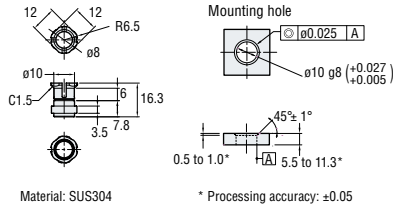

Sensor head cable (straight)/(oil-resistant straight)  
**GT2-CH2M/5M/10M/20M (Optional)**  
**GT2-CHP2M/5M/10M (Optional)**

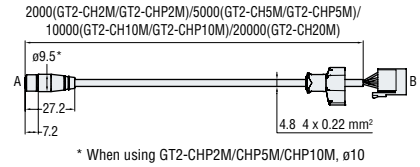

Sensor head mounting bracket C (Optional)  
**OP-84396**

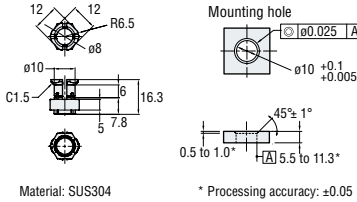

Sensor head cable (L-shaped)  
**GT2-CHL2M/5M/10M/20M (Optional)**

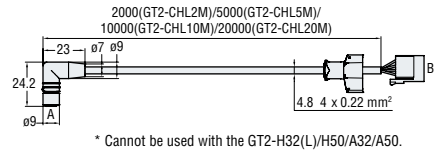

Sensor head mounting bracket B (Optional)  
**OP-76875**



Sensor head mounting bracket E (Optional)  
**OP-87220**

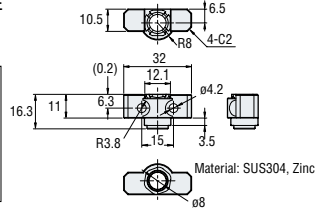

Pin arrangement  
Sensor head cable (straight/L-shaped)

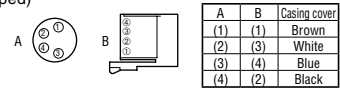

Dustboot



Sensor head mounting bracket D (Optional)  
**OP-84327**

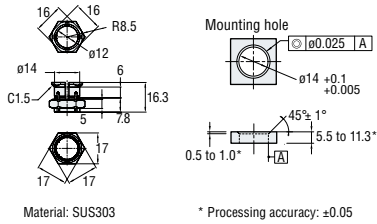

**OP-84332**

Applicable models  
GT2-P12K(F)/P12(F)  
GT2-H12K(F)/H12(F)  
GT2-A12K/A12  
Materials: NBR, SUS304  
\* Attached to the sensor head.  
(Excluding the low stress type)

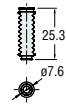

**OP-87859 (Optional)**

Applicable models  
GT2-P12K(F)/P12(F)  
Materials: Fluorocarbon rubber, SUS304

Sensor head mounting bracket F (Optional)  
**OP-87863**

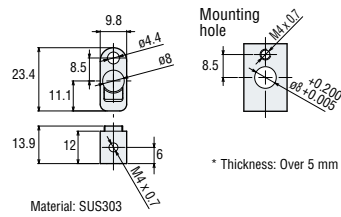

**OP-84459**

Applicable models  
GT2-H32  
GT2-A32  
\* Attached to the sensor head.

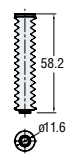

**OP-84460**

Applicable models  
GT2-H50  
GT2-A50  
\* Attached to the sensor head.

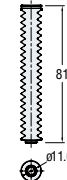

Replacement dust seal

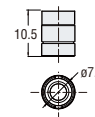

**OP-87932**

Applicable models  
GT2-PA12(K)  
\* Attached to the sensor head.

Contact

Standard  
**OP-77678**



Material:  
OP-77678  
SUS304  
SUS440C

Super-tough  
**OP-77682**

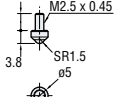

OP-77682  
SUS304  
Super-tough tungsten alloy

Standard (small)  
**OP-87984**



Material:  
OP-87984  
SUS304  
SUS440C

Super-tough (small)  
**OP-87985**

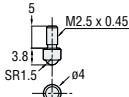

OP-87985  
SUS304  
Super-tough tungsten alloy

Flat plate (Optional)  
**OP-77679**



Material: SUS304  
Super-tough tungsten alloy

Roller (Optional)  
**OP-77680**



Material: SUS304  
SUS440C

Fluorocarbon resin (Optional)  
**OP-80228**



Material:  
Fluorocarbon resin (PTFE)

Ceramic (Optional)  
**OP-81970**



Material: SUS304, Ceramic

Needle (Optional)  
**OP-77681**



Material: SUS304  
Super-tough tungsten alloy

Offset (Optional)  
**OP-77683**



Material: SUS304  
Super-tough tungsten alloy

Spacer (Optional)  
**OP-77684**



Material: SUS304

Roller (high-accuracy) (Optional)  
**OP-93332**



Material: SUS304  
SUS303  
SUS440C

# INPUT/OUTPUT CIRCUIT DIAGRAMS

## I/O circuit GT2-71N/72N/71CN/72CN/71MCN/75N/76N

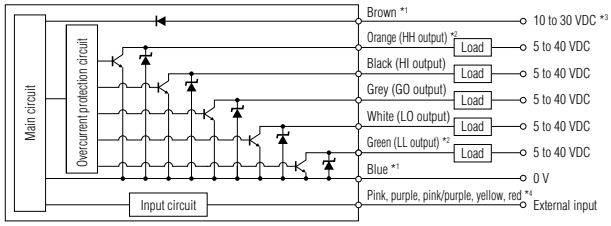

## External input circuit

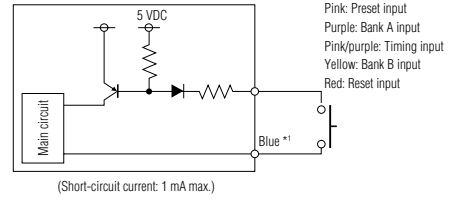

## I/O circuit GT2-71P/72P/71CP/72CP/71MCP/75P/76P

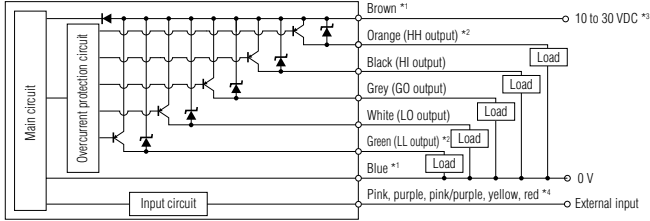

## External input circuit

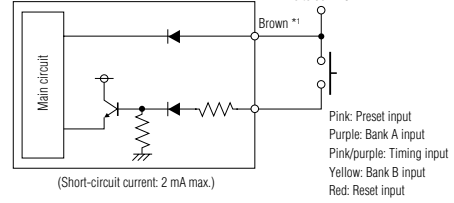

- \*1 Brown and blue are applicable only to main units (GT2-71N/71P/71CN/71CP/71MCN/71MCP/75N/75P). Not applicable to expansion units (GT2-72N/72P/72CN/72CP/76N/76P). The connector type expansion unit (GT2-72CN/72CP) is not connected to the internal circuit.
- \*2 The orange and green wires are used as analogue output cables for the analogue type amplifier unit (GT2-71MCN/71MCP). For details, refer to the analogue output circuit diagram.
- \*3 20 to 30 VDC when expansion unit is connected or for the analogue type amplifier unit (GT2-71MCN/71MCP).
- \*4 For details on external input, refer to the external input circuit diagram.

## Analogue output circuit GT2-71MCN/71MCP

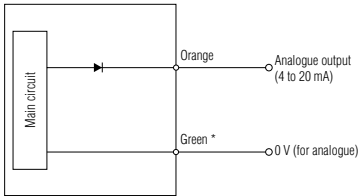

- \* The green and blue wires are common internally.

## Pulse output amplifier unit GT2-71D I/O circuit

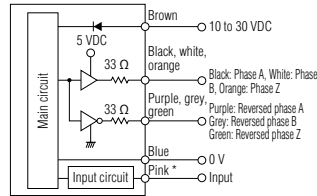

- \* For details of the external input, refer to the diagram of the external input circuit.

## External input circuit

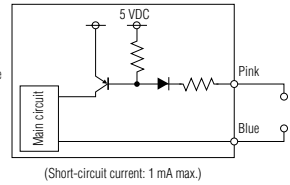

## Recommended input device

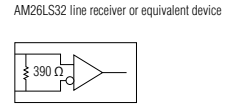

## Output circuit of the large display amplifier unit GT2-100N/GT2-E3N

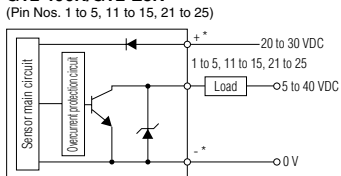

- \* The +/- terminals are provided in the GT2-100N only. They are not provided in the GT2-E3N.

## Input circuit of the large display amplifier unit GT2-100N/GT2-E3N

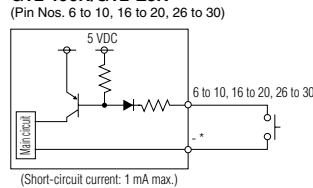

- \* The - terminal is provided in the GT2-100N only. It is not provided in the GT2-E3N.

## Multi-head amplifier unit GT2-500 (main unit)

The power supply cable is as follows.

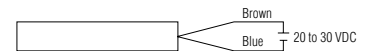

## Output circuit of the large display amplifier unit GT2-100P/GT2-E3P

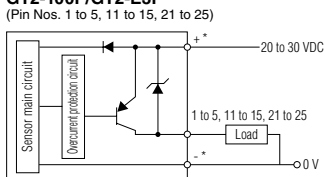

- \* The +/- terminals are provided in the GT2-100P only. They are not provided in the GT2-E3P.

## Input circuit of the large display amplifier unit GT2-100P/GT2-E3P

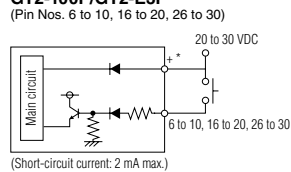

- \* The + terminal is provided in the GT2-100P only. It is not provided in the GT2-E3P.



Please visit: [www.keyence.com](http://www.keyence.com)



**SAFETY INFORMATION**

Please read the instruction manual carefully in order to safely operate any KEYENCE product.

**GLOBAL NETWORK**

CONTACT YOUR NEAREST OFFICE FOR RELEASE STATUS

**AUSTRIA**  
Phone: +43-2236-378266-0

**CZECH REPUBLIC**  
Phone: +420-222-191-483

**INDIA**  
Phone: +91-44-4963-0900

**MALAYSIA**  
Phone: +60-3-7883-2211

**ROMANIA**  
Phone: +40-269-232-808

**TAIWAN**  
Phone: +886-2-2721-8080

**BELGIUM**  
Phone: +32-15-281-222

**FRANCE**  
Phone: +33-1-56-37-78-00

**INDONESIA**  
Phone: +62-21-2966-0120

**MEXICO**  
Phone: +52-55-8850-0100

**SINGAPORE**  
Phone: +65-6392-1011

**THAILAND**  
Phone: +66-2-369-2777

**BRAZIL**  
Phone: +55-11-3045-4011

**GERMANY**  
Phone: +49-6102-3689-0

**ITALY**  
Phone: +39-02-6688220

**NETHERLANDS**  
Phone: +31-40-20-66-100

**SLOVAKIA**  
Phone: +421-25939-6461

**UK & IRELAND**  
Phone: +44 (0) 1908-696-900

**CANADA**  
Phone: +1-905-366-7655

**HONG KONG**  
Phone: +852-3104-1010

**JAPAN**  
Phone: +81-6-6379-2211

**PHILIPPINES**  
Phone: +63-(0) 2-981-5000

**SLOVENIA**  
Phone: +386-1-4701-666

**USA**  
Phone: +1-201-930-0100

**CHINA**  
Phone: +86-21-5058-6228

**HUNGARY**  
Phone: +36-1-802-73-60

**KOREA**  
Phone: +82-31-789-4300

**POLAND**  
Phone: +48-71-36861-60

**SWITZERLAND**  
Phone: +41-43-455-77-30

**VIETNAM**  
Phone: +84-4-3772-5555